



TVS

TVS

概述 Description

SPC6采用SMT0-218封装，相比典型的轴向型TVS管，制造工艺更为简单，质量更为可靠。可被串联或并联在电路中提供各种功能灵活的电路保护解决方案。

The SPC6 in SMT0-218 package provide the enhanced quality, easy manufacturing than typical through-hole TVS components. They can be connected in series and/or parallel to create various capability and flexible protection solutions.

应用 Applications

- 通信设备 Communication Equipment
- 安防 Security & Protection
- 工控设备 Industrial Control Equipment
- 电源 Power Supply
- 汽车电子 Automotive Electronics
- 新能源设备 New Energy
- 防雷保护 Lightning Protection

功能图 Functional Diagram



双极性

Bi-Directional

特性 Features

- 双极性
 - 低箝位电压，低斜率电阻
 - 用于自动取放组装和回流工艺，与轴向引线封装相比，降低制造成本，提高焊接质量
 - 紧凑型表贴封装
 - 湿度敏感等级1，峰值温度245 °C
 - 无铅E3：二级互联无铅，引脚镀锡
 - ESD符合IEC 61000-4-2标准
 - 无卤，符合RoHS指令
 - 管装及编带卷盘包装可选
-
- Bi-directional
 - Low clamping and slope resistance
 - For automatic pick and place assembly and reflow process to reduce the manufacturing cost and increase the soldering quality compared to axial leads package
 - Compact surface mount package design
 - Meet MSL level 1, per J-STD-020, LF Maximum peak of 245 °C
 - Pb-free E3 means 2nd level interconnect is Pb-free and the terminal finish material is tin (Sn)
 - ESD follow IEC 61000-4-2
 - Halogen free and RoHS compliant
 - Tube or tape and reel pack options available

型号规则 Part Numbering System

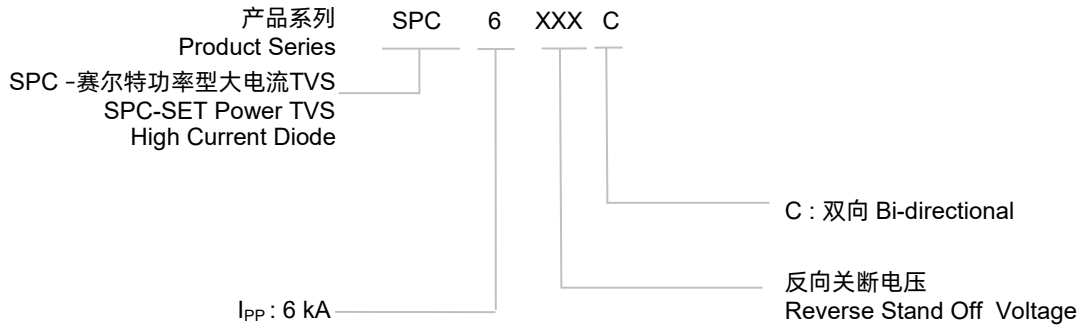

标识 Marking

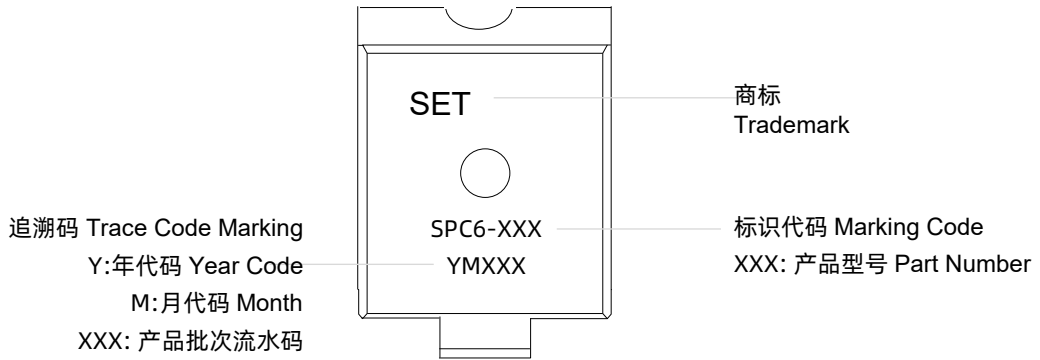

TVS

TVS

术语 Glossary

项目 Item	描述 Description
V_C	箝位电压 Clamping Voltage TVS在低差阻区域内的电压，用于限制设备两端的电压。 Voltage across TVS in a region of low differential resistance that serves to limit the voltage across the device terminals.
V_R	反向关断电压 Reverse Stand-off Voltage TVS 在没有导通状态下最高电压。 Maximum voltage that can be applied to the TVS without operation. 注：也用 V_{WM} （最高直流工作电压）表示，也称为截止电压(V_{SO})。 NOTE : It is also shown as V_{WM} (maximum working voltage (maximum d.c. voltage)) and known as rated stand-off voltage (V_{SO}).
I_R	反向漏电流 Reverse Leakage Current 量测 V_R 的电流。 Current measured at V_R . 注：也用 I_D 待机电流表示。 NOTE : Also shown as I_D for stand-by current.
V_{BR}	击穿电压 Breakdown Voltage 在击穿区以指定电流 I_T (测试电流)通过TVS的电压。 Voltage across TVS at a specified current I_T (test current) in the breakdown region.
I_{PPM}	额定随机重复峰值脉冲电流 Rated Random Recurring Peak Impulse Current 施加在设备上的随机重复峰值脉冲电流的最大额定值。 Maximum-rated value of random recurring peak impulse current that may be applied to a device.
$P_{M(AV)}$	额定平均功率 Rated Average Power Dissipation 所有电源(包括瞬态电流和待机电流)在短时间内平均产生的最大额定功耗。 Maximum-rated value of power dissipation resulting from all sources, including transients and standby current, averaged over a short period of time.
P_{PPM}	额定随机重复峰值脉冲功率 Rated Random Recurring Peak Impulse Power Dissipation 额定随机重复峰值脉冲电流(I_{PPM}) 和规定的最大箝位电压(V_C)乘积的最大额定值。 Maximum-rated value of the product of rated random recurring peak impulse current (I_{PPM}) multiplies by specified maximum clamping voltage (V_C).
C_J	电容 Capacitance 在规定的频率和电压下所测量的TVS电容。 Capacitance across the TVS measured at a specified frequency and voltage.

—(GB-T 18802.321 / IEC 61643-321 / JESD210A)

瞬态抑制二极管 TVS Diodes

Transient Voltage Suppression Diodes

SPC6 Series (6KA)

项目 Item	描述 Description
V_{FS}	<p>正向浪涌峰值电压 Peak Forward Surge Voltage 在指定的正向浪涌电流(I_{FS})和持续时间下, 通过TVS的峰值电压。 Peak voltage across TVS for a specified forward surge current (I_{FS}) and time duration. 注: 也用V_F表示。 NOTE : Also shown as V_F.</p>
I_{FS}	<p>正向浪涌电流 Forward Surge Current 在正向导通区域通过TVS的脉冲电流。 Pulsed current through TVS in the forward conducting region. 注: 也用I_F表示。 NOTE : Also shown as I_F.</p>
$\alpha_{V(BR)}$	<p>击穿电压温度系数 Temperature Coefficient of Breakdown Voltage 击穿电压的变化与温度变化的比值。 The change of breakdown voltage divided by the change of temperature.</p>
I_{PP}	<p>峰值脉冲电流 Peak pulse Current 施加在TVS上的峰值脉冲电流, 以确定箝位电压V_C的特定波形。 Peak pulse current value applied across the TVS to determine the clamping voltage V_C for a specified wave shape.</p>
I_T	<p>脉冲直流测试电流 Pulsed D.C. Test Current 测量击穿电压V_{BR}的测试电流。该电流值由制造商确定, 通常以脉冲持续时间小于40 ms的毫安级电流给出。 Test current for measurement of the breakdown voltage V_{BR}. This is defined by the manufacturer and usually given in milliamperes with a pulse duration of less than 40 ms. 注: 也用I_{BR}表示。 NOTE : Also shown as I_{BR}.</p>

—(GB-T 18802.321 / IEC 61643-321 / JESD210A)

TVS

TVS

瞬态抑制二极管 TVS Diodes

Transient Voltage Suppression Diodes

SPC6 Series (6KA)

电性参数 Electrical Characteristics

(T_A=25 °C unless otherwise noted)

型号 Part Number	关断电压 Stand-off Voltage V _R	最大反向 漏电流 Max. Reverse Leakage I _R @V _R	击穿电压 Breakdown Voltage V _{BR} @I _T Min Max		测试电流 Test Current I _T	最大箝位电压 Max. Clamping Voltage V _{CL} @Peak Pulse Current (I _{PP})			最大温度 系数 Max. Temp Coefficient of V _{BR}	最大容值 Max. Capacitance 0 Bias 10KHz
			Min	Max		V _{CL}	I _{PP} (8/20 μS)	I _{PP} (10/350 μS)		
							Min	Typical		
(V)	(μA)	(V)		(mA)	(V)	(A)	(A)	(%/°C)	(nF)	
SPC6-058C	58	10	64	70	10	110	6000	900	0.1	6.5
SPC6-066C	66	10	72	80	10	120	6000	900	0.1	5.5
SPC6-076C	76	10	85	95	10	140	6000	900	0.1	4.5

TVS

TVS

瞬态抑制二极管 TVS Diodes

Transient Voltage Suppression Diodes

SPC6 Series (6KA)

封装尺寸 Package Outline Dimensions (SMTO-218)

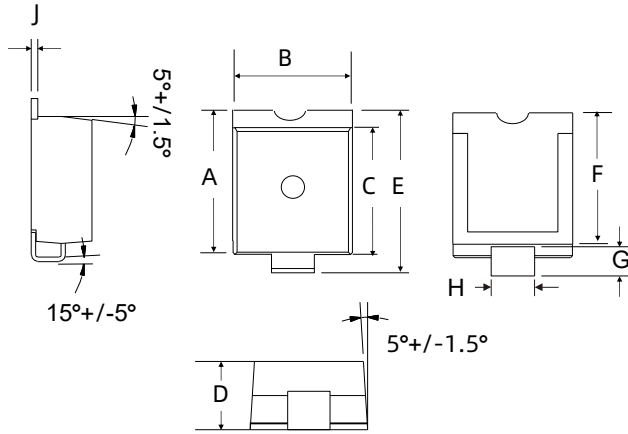

注: 焊锡面共面度控制在0.10 mm 以内
 Note: Coplanarity of solder side is controlled within 0.10 mm

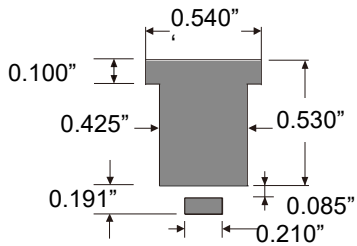

安装布局
 Mounting Pad Layout (Inch)

符号 Symbol	公制(毫米) Millimeters		英制(英寸) Inches	
	Min.	Max.	Min.	Max.
A	15.78	16.63	0.621	0.655
B	13.43	15.09	0.529	0.594
C	13.83	14.24	0.544	0.561
D	6.94	7.24	0.273	0.285
E	17.82	18.72	0.702	0.737
F	14.40	14.76	0.567	0.581
G	1.88	2.84	0.074	0.112
H	4.89	5.65	0.193	0.222
J	0.72	0.85	0.028	0.033

最大额定值及特性 Maximum Ratings and Characteristics

(额定环境温度为25 °C, 除非另有规定 Ratings at 25 °C ambient temperature unless otherwise specified.)

参数 Parameter	符号 Symbol	值 Value	单位 Unit
存储温度范围 Storage Temperature Range	T _{STG}	-55 to 150	°C
工作温度 Operating Junction	T _J	-55 to 125	°C
额定电流 Current Rating (8/20 μs wave)	I _{PP}	10	kA

物理特性 Physical Specifications

重量 Weight	Contact manufacturer
封装 Case	Epoxy molding compound encapsulated
端子 Terminal	Tin plated lead, solderability per MIL-STD-202 Method 208

环境特性 Environmental Specifications

温度循环 Temperature Cycling	JESD22-A104
高温反偏 HTRB	JESD22-A108
湿度敏感等级 MSL	JESDEC-J-STD-020, Level 1
高温高湿反偏 H3TRB	JESD22-A101
耐焊接热 RSH	JESD22-B106

伏安特性曲线 I-V Curve Characteristics

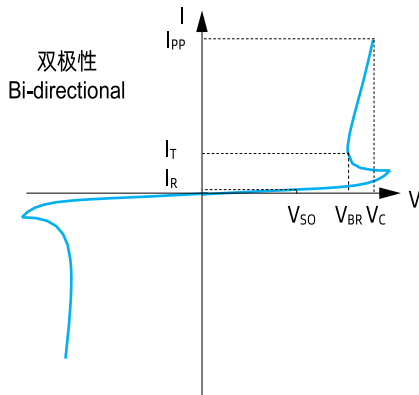

- I_{PP} - 峰值脉冲电流 Peak Pulse Current
- V_{SD} - 关断电压 Stand-off Voltage
- V_{BR} - 击穿电压 Breakdown Voltage
- V_C - 箝位电压 Clamping Voltage
- I_R - 反向漏电流 Reverse Leakage Current

性能参考曲线 Performance Curve for Reference

(额定环境温度为25 °C, 除非另有规定 $T_A=25\text{ °C}$ unless otherwise noted)

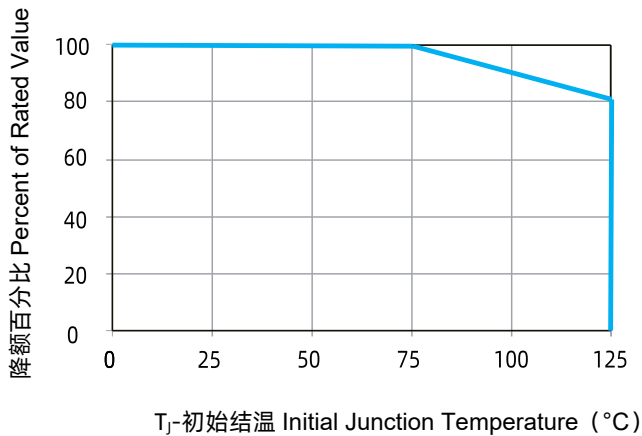

FIGURE 1 峰值功率降额 Peak Power Derating

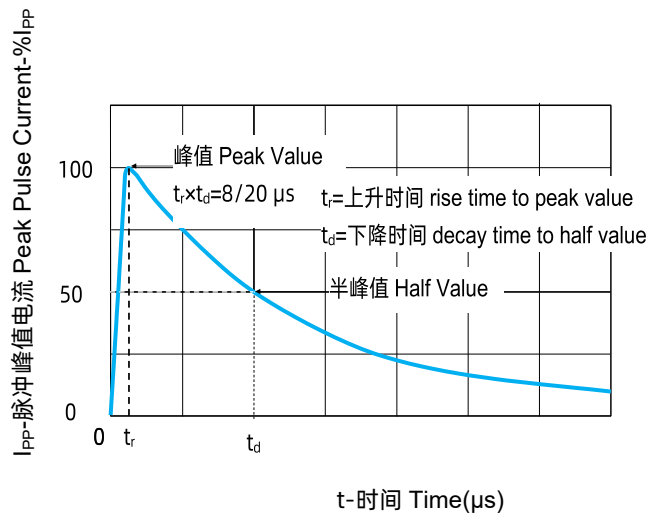

FIGURE 2 脉冲波形 Pulse Waveform

瞬态抑制二极管 TVS Diodes

Transient Voltage Suppression Diodes

SPC6 Series (6KA)

焊接参数 Soldering Parameters

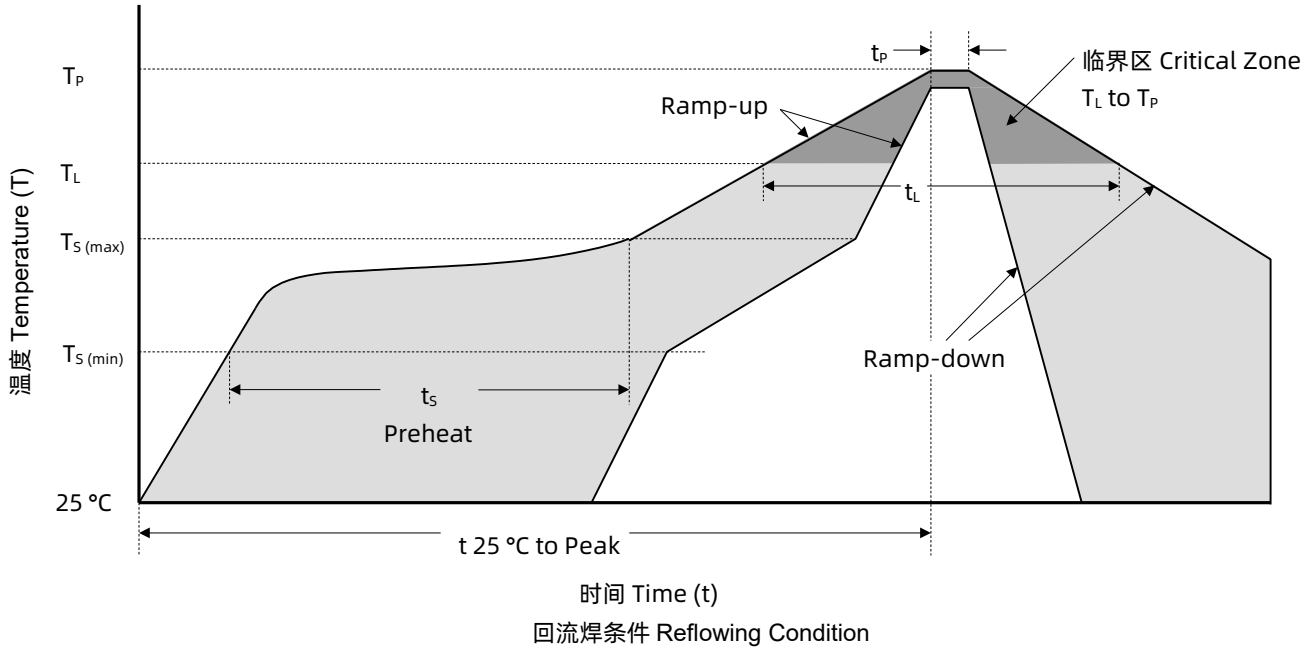

回流焊接参数 Reflow Soldering Parameters		无铅组装 Lead-Free Assembly
预热 Pre-heat	最低温($T_{S(min)}$) Temperature Min ($T_{S(min)}$)	150 °C
	最高温($T_{S(max)}$) Temperature Max ($T_{S(max)}$)	200 °C
	升温时长(t_s) Time (min to max) (t_s)	60 ~ 120 seconds
平均升温速率(液相温度(T_L)至峰值温度(T_P)) Average Ramp-up Rate (Liquidus Temp (T_L) to Peak Temp (T_P))		3 °C / second max.
$T_{S(max)}$ 到 T_L 升温速率 $T_{S(max)}$ to T_L Ramp-up Rate		3 °C / second max.
回流 Reflow	温度 Temperature (T_L) (Liquidus)	217 °C
	时长 Time (min to max) (t_L)	60 ~ 150 seconds
峰值温度 Peak Temperature (T_P)		260 ^{+0/-5} °C
实际峰值温度 (t_p) 5 °C 以内的时间 Time of within 5 °C of Actual Peak Temperature (t_p)		20 ~ 40 seconds
降温速率 Ramp-down Rate		6 °C / second max.
25 °C 至峰值温度时长 Time from 25 °C to Peak Temperature		8 Minutes max.
极限温度 Do Not Exceed		260 °C

波峰焊 Wave Soldering (浸焊 Solder Dipping)

峰值温度 Peak Temperature	260 °C
浸润时间 Dipping Time	10 seconds
焊接次数 Soldering Number	1 time

包装信息 Packaging Information

编带 Tape	符号 Symbol	公制 Millimeters	英制 Inches
	W	32 ± 0.3	1.260 ± 0.012
	E	1.75 ± 0.1	0.069 ± 0.004
	F	14.2 ± 0.1	0.559 ± 0.004
	D ₀	1.5 + 0.1/0.0	0.059 + 0.004/-0.0
	P ₀	4.0 ± 0.1	0.102 ± 0.004
	P ₁	20.0 ± 0.1	0.787 ± 0.004
	P ₂	2.0 ± 0.1	0.079 ± 0.004
	A ₀	14.5 ± 0.1	0.571 ± 0.004
	B ₀	18.5 ± 0.1	0.728 ± 0.004
	T	0.40	0.016
	T ₁	7.8	0.029

	符号 Symbol	公制(毫米) Millimeters	英制(英寸) Inches
	D	Φ13	Φ330.0
	D ₁	Φ0.520 ± 0.008	Φ13.2 ± 0.2
	W ₁	1.417 ± 0.079	36.0 ± 2.0

型号 Part Number	重量 Weight	包装选项 Packaging Option	数量 QTY' s
SPC6-XXXXC	4.33 g	Tape & Reel – 32mm/13" tape	400 PCS



注意

ATTENTION

使用方法 Usage

1. 请在规定的温度范围内使用TVS。
TVS must be operated in the specified ambient temp.
2. 请勿使用强极性溶剂清洗TVS以免破坏封装层。
Do not clean the TVS with strong polar solvent such as ketone, esters, benzene and halogenated hydrocarbon, to avoid damaging the encapsulating layer.
3. 请勿对TVS施加剧烈的振动，冲击或压力，以避免元件开裂。
Please do not apply severe vibration, shock or pressure to TVS, to avoid element cracking.

更换 Replacement

1. 若TVS出现可视化损伤，请将其更换。
If TVS is visually damaged, please replace it.
2. TVS为非修理型产品，安全起见，请更换同等规格的TVS。
TVS is a non-repairable product. For safety sake, please use equivalent TVS for replacement.

存储 Storage

1. 存储温度范围。
Storage Temp. Range: (-55 to 150) °C.
2. 请勿将TVS存放于高温高湿或腐蚀性气体环境中，已避免影响引脚的焊接性能，请于收货后一年内进行使用。
Do not store the TVS at the high temp., high humidity or corrosive gas environment, to avoid influencing the solder-ability of the lead wires. The product shall be used up within 1 year after receiving the goods.

环境条件 Environmental Conditions

1. 请勿暴露于室外阳光直射环境。
TVS should not be exposed to the open air, nor direct sunshine.
2. 请避免雨水，水汽等高温高湿环境。
TVS should avoid rain, water vapor or other condition of high temp. and high humidity.
3. 请避免沙尘，盐雾等有害环境。
TVS should avoid sand dust, salt mist, or other harmful gases.

TVS最大典型结电容 Max. Typical Capacitance of TVS

高频线路应用中请参照规格书中所给出的典型电容曲线。

The typical capacitance of TVS is listed in the specifications. Designers may refer to it when designing TVS in high frequency circuit.

安装机械应力 Installation Mechanical Stress

1. 安装TVS时请避免敲击，防止物理损伤。
Do not knock TVS when installing, to avoid mechanical damage.
2. 请不要对 TVS 施加剧烈的振动、冲击或压力，以免表面树脂或元件破裂。
Please do not apply severe vibration, shock or pressure to TVS, to avoid surface resin or element cracking.