

热保护型压敏电阻 TFMOV

Thermal Fuse & MOV

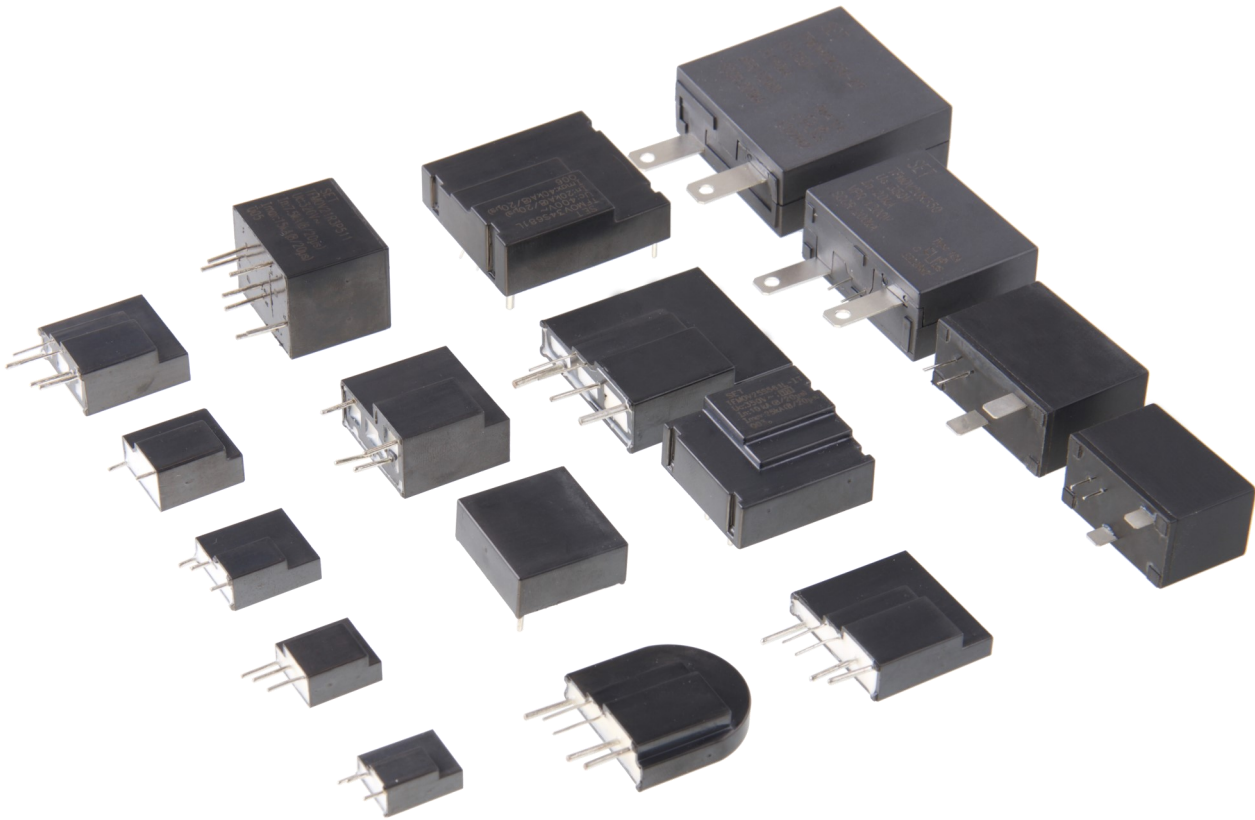

特性 Features

- 高可靠性 High Reliability
- 小体积 Small Size
- 失效指示遥信引脚(可选)
Remote Signal Contact for Failure Indication (Optional)
- 高通流量 High Energy Capacity
- 密封材料阻燃等级V0
Sealing Material, Flame-retardant to V0 (UL 94)
- 依据 UL 1449 / IEC 61643-11 设计制造
Comply with UL 1449 / IEC 61643-11

应用 Applications

- 通信设备 Telecom Equipment
- 组串逆变器 String Inverter in Photovoltaic System
- 交直流电源 AC / DC Power Supply
- 不间断电源 Uninterruptable Power Supply (UPS)
- 电涌保护器 Surge Protective Device (SPD)
- 电表 Electric Meter
- 电源分配单元 Power Distribution Unit (PDU)

热保护型压敏电阻特性与型号概览
Thermal Fuse & MOV (TFMOV) Feature & Model List Overview

额定电压 U_n (V)		标称放电电流 I_n (kA)										页码 Page		型号 Model	最大连续工作电压 Maximum Continuous Operating Voltage U_n (V)
AC	DC	1	1.5	2.5	3	4	5	AC	DC						
690V	600V	○	○	○	○	○	○	○	○	○	○	750	1000	最大连续工作电压 Maximum Continuous Operating Voltage U_n (V)	
		○	○	○	○	○	○	○	○	○	○	680	895		
480V		○	○	○	○	○	○	○	○	○	○	625	825		
	400V	○	○	○	○	○	○	○	○	○	○	550	745		
347V		○	○	○	○	○	○	○	○	○	○	510	670		
	254	○	○	○	○	○	○	○	○	○	○	460	615		
	277V	○	○	○	○	○	○	○	○	○	○	420	560		
220	230V	○	○	○	○	○	○	○	○	○	○	385	505		
	300V	○	○	○	○	○	○	○	○	○	○	350	460		
		○	○	○	○	○	○	○	○	○	○	320	415		
	120	○	○	○	○	○	○	○	○	○	○	300	385		
	130V	○	○	○	○	○	○	○	○	○	○	275	350		
	220V	○	○	○	○	○	○	○	○	○	○	250	320		
		○	○	○	○	○	○	○	○	○	○	230	300		
	110V	○	○	○	○	○	○	○	○	○	○	210	275		
		○	○	○	○	○	○	○	○	○	○	190	250		
		○	○	○	○	○	○	○	○	○	○	175	225		
		○	○	○	○	○	○	○	○	○	○	150	200		
110V		○	○	○	○	○	○	○	○	○	○	140	180		
		○	○	○	○	○	○	○	○	○	○	130	170		
		○	○	○	○	○	○	○	○	○	○	115	150		
	60V	○	○	○	○	○	○	○	○	○	○	95	125		
48V	60V	○	TFMOV10S121	TFMOV15S121	TFMOV20S560Lx	○	○	TFMOV20S181Lx	TFMOV15S181	TFMOV20S181	○	75	100		
	48V	○	TFMOV10S101	TFMOV15S101	TFMOV20S470Lx	○	○	TFMOV20S121Lx	○	TFMOV20S121x	○	60	85		
	36V	○	TFMOV10S820	TFMOV15S820	○	○	TFMOV20S101Lx	○	TFMOV20S101x	○	○	50	65		
			TFMOV10S680	TFMOV15S680	TFMOV20S680x	○	○	TFMOV20S820Lx	○	TFMOV20S820x	○	40	56		
	24V		TFMOV10S560	TFMOV15S560	TFMOV20S560x	○	○	○	○	TFMOV25S680x	TFMOV25S680Lx	35	45		
			TFMOV10S470	TFMOV15S470	TFMOV20S470x	○	○	○	○	TFMOV25S560x	TFMOV25S560Lx	30	38		
			TFMOV10S390	TFMOV15S390	○	○	○	○	○	○	○	25	31		
	12V		TFMOV10S330	TFMOV15S330	○	○	○	○	○	○	○	20	26		
			TFMOV10S270	TFMOV15S270	○	○	○	○	○	○	○	17	22		

热保护型压敏电阻特性与型号概览
Thermal Fuse & MOV (TFMOV) Feature & Model List Overview

额定电压 Rated Voltage U_n (V)		型号 Model										最大连续工作电压 Maximum Continuous Operating Voltage U_n (V)		页码 Page			
AC	DC	7.5	8	10	10	10	10	10	10	10	10	10	10	15	AC	DC	
690V	600V	TFMOV20S122x					TFMOV25D122x	TFMOV25S122x							750	1000	
		TFMOV20S112x					TFMOV25D112x	TFMOV25S112x								680	895
480V	400V	TFMOV20S102x					TFMOV25D102x	TFMOV25S102x							625	825	
		TFMOV20S911x					TFMOV25D911x	TFMOV25S911x							550	745	
347V	254 - 277V	TFMOV20S821x					TFMOV25D821x	TFMOV25S821x							510	670	
		TFMOV20S751x					TFMOV25D751x	TFMOV25S751x							460	615	
220 - 230V	300V	TFMOV20S681x	TFMOV20S681Lx				TFMOV25D681x	TFMOV25S681x	TFMOV25S681Lx						420	560	
		TFMOV20S621x	TFMOV20S621Lx				TFMOV25D621x	TFMOV25S621x	TFMOV25S621Lx						385	505	
120 - 130V	220V	TFMOV20S561x	TFMOV20S561Lx				TFMOV25D561x	TFMOV25S561x	TFMOV25S561Lx						350	460	
		TFMOV20S511x	TFMOV20S511Lx				TFMOV25D511x	TFMOV25S511x	TFMOV25S511Lx						320	415	
110V	110V	TFMOV20S471x	TFMOV20S471Lx				TFMOV25D471x	TFMOV25S471x	TFMOV25S471Lx						300	385	
		TFMOV20S431x	TFMOV20S431Lx				TFMOV25D431x	TFMOV25S431x	TFMOV25S431Lx						275	350	
60V	60V	TFMOV20S391x	TFMOV20S391Lx				TFMOV25D391x	TFMOV25S391x	TFMOV25S391Lx						250	320	
		TFMOV20S361x	TFMOV20S361Lx				TFMOV25D361x	TFMOV25S361x	TFMOV25S361Lx						230	300	
48V	48V	TFMOV20S331x	TFMOV20S331Lx				TFMOV25D331x	TFMOV25S331x	TFMOV25S331Lx						210	275	
		TFMOV20S301x	TFMOV20S301Lx				TFMOV25D301x	TFMOV25S301x	TFMOV25S301Lx						190	250	
36V	36V	TFMOV20S271x	TFMOV20S271Lx				TFMOV25D271x	TFMOV25S271x	TFMOV25S271Lx						175	225	
		TFMOV20S241x	TFMOV20S241Lx				TFMOV25D241x	TFMOV25S241x	TFMOV25S241Lx						150	200	
24V	24V	TFMOV20S221x	TFMOV20S221Lx				TFMOV25D221x	TFMOV25S221x	TFMOV25S221Lx						140	180	
		TFMOV20S201x	TFMOV20S201Lx				TFMOV25D201x	TFMOV25S201x	TFMOV25S201Lx						130	170	
12V	12V			TFMOV25S181x	TFMOV25S181Lx								TFMOV20K181x	115	150		
				TFMOV25S151x	TFMOV25S151Lx								TFMOV20K151x	95	125		
				TFMOV25S121x	TFMOV25S121Lx							TFMOV34S121x	75	100			
				TFMOV25S101x	TFMOV25S101Lx							TFMOV34S101x	60	85			
				TFMOV25S820x	TFMOV25S820Lx							TFMOV34S820x	50	65			
							TFMOV34S680x					TFMOV34S680Lx	40	56			
							TFMOV34S560x					TFMOV34S560Lx	35	45			
							TFMOV34S470x					TFMOV34S470Lx	30	38			
													25	31			
													20	26			
													17	22			

$I_{max} = 2.5/I_n$

标称放电电流 Nominal Discharge Current I_n (kA)

热保护型压敏电阻特性与型号概览
Thermal Fuse & MOV (TFMOV) Feature & Model List Overview

额定电压 U_n (V)		型号 Model								最大连续工作电压 U_n (V)		页码 Page
AC	DC	15	20	20	30	40	AC	DC	750	1000		
690V	600V	○	TFMOV20K122x	○	TFMOV34S122x	○	○	TFMOV40K122x	○	750	1000	最大连续工作电压 Maximum Continuous Operating Voltage U_n (V)
		○	TFMOV20K112x	○	TFMOV34S112x	○	○	TFMOV40K112x	○	680	895	
	480V	○	TFMOV20K102x	○	TFMOV34S102x	○	○	TFMOV40K102x	○	625	825	
		400V	○	TFMOV20K911x	TFMOV20K550x	TFMOV34S911x	○	○	TFMOV40K911x	TFMOV40K550x	550	
	347V	○	TFMOV20K821x	○	TFMOV34S821x	○	○	TFMOV40K821x	○	510	670	
		○	TFMOV20K751x	TFMOV20K460x	TFMOV34S751x	○	○	TFMOV40K751x	TFMOV40K460x	460	615	
	254 - 277V	○	TFMOV20K681x	○	TFMOV34S681x	TFMOV34S681Lx	○	TFMOV40K681x	○	420	560	
		○	TFMOV20K621x	○	TFMOV34S621x	TFMOV34S621Lx	○	TFMOV40K621x	○	385	505	
	220 - 230V	○	TFMOV20K561x	TFMOV20K350x	TFMOV34S561x	TFMOV34S561Lx	○	TFMOV40K561x	TFMOV40K350x	350	460	
		300V	○	TFMOV20K511x	○	TFMOV34S511x	TFMOV34S511Lx	○	TFMOV40K511x	○	320	
	120 - 130V	○	TFMOV20K471x	○	TFMOV34S471x	TFMOV34S471Lx	○	TFMOV40K471x	○	300	385	
		○	TFMOV20K431x	TFMOV20K300x	TFMOV34S431x	TFMOV34S431Lx	○	TFMOV40K431x	TFMOV40K300x	275	350	
110V	220V	○	TFMOV20K391x	○	TFMOV34S391x	TFMOV34S391Lx	○	TFMOV40K391x	○	250	320	
	○	TFMOV20K361x	○	TFMOV34S361x	TFMOV34S361Lx	○	TFMOV40K361x	○	230	300		
60V	60V	○	TFMOV20K331x	○	TFMOV34S331x	TFMOV34S331Lx	○	TFMOV40K331x	○	210	275	
		○	TFMOV20K301x	○	TFMOV34S301x	TFMOV34S301Lx	○	TFMOV40K301x	○	190	250	
48V	48V	○	TFMOV20K271x	○	TFMOV34S271x	TFMOV34S271Lx	○	TFMOV40K271x	○	175	225	
		○	TFMOV20K241x	TFMOV20K150x	TFMOV34S241x	TFMOV34S241Lx	○	TFMOV40K241x	TFMOV40K150x	150	200	
36V	36V	○	TFMOV20K221x	○	TFMOV34S221x	TFMOV34S221Lx	○	TFMOV40K221x	○	140	180	
		○	TFMOV20K201x	○	TFMOV34S201x	TFMOV34S201Lx	○	TFMOV40K201x	○	130	170	
24V	24V	○	○	○	TFMOV34S181x	TFMOV34S181Lx	○	TFMOV40K181x	○	115	150	
		○	○	○	TFMOV34S151x	TFMOV34S151Lx	○	○	○	95	125	
12V	12V	TFMOV34S121Lx	○	○	○	○	○	○	75	100		
		TFMOV34S101Lx	○	○	○	○	TFMOV40K121x	○	60	85		
12V	12V	TFMOV34S820Lx	○	○	○	○	TFMOV40K101x	○	50	65		
		○	○	○	○	○	TFMOV40K820x	○	40	56		
12V	12V	○	○	○	○	○	○	○	35	45		
		○	○	○	○	○	○	○	30	38		
12V	12V	○	○	○	○	○	○	○	25	31		
		○	○	○	○	○	○	○	20	26		
12V	12V	○	○	○	○	○	○	○	17	22		
		○	○	○	○	○	○	○	17	22		

$I_{max} = 2.5 I_n$

标称放电电流 Nominal Discharge Current I_n (kA)

热保护型压敏电阻特性与型号概览
Thermal Fuse & MOV (TFMOV) Feature & Model List Overview

额定电压 U_n (V)		型号 Model						最大连续工作电压 U_n (V)	
AC	DC	2.5 x 2	5 x 2	7.5 x 2	2.5 x 3	5 x 3	7.5 x 3	AC	DC
690V	600V	○	○	○	○	○	○	750	1000
		○	○	○	○	○	○	680	895
480V		○	○	○	○	○	○	625	825
	400V	○	○	○	○	○	○	550	745
347V		○	○	○	○	○	○	510	670
	254	○	○	○	○	○	○	460	615
	277V	○	○	○	○	○	○	420	560
220		○	○	TFMOV21R2P511	○	○	○	385	505
	230V	○	○	TFMOV21R2P471	○	○	TFMOV21R3P511	350	460
	300V	○	○	TFMOV21R2P431	○	○	TFMOV21R3P471	320	415
		○	○	TFMOV21R2P391	○	○	TFMOV21R3P431	300	385
	120	○	○	TFMOV21R2P361	○	○	TFMOV21R3P391	275	350
	130V	○	○	TFMOV21R2P331	○	○	TFMOV21R3P361	250	320
		○	○	TFMOV21R2P301	○	○	TFMOV21R3P331	230	300
		○	○	TFMOV21R2P271	○	○	TFMOV21R3P301	210	275
		○	○	TFMOV21R2P241	○	○	TFMOV21R3P271	190	250
110V	110V	○	○	TFMOV21R2P221	○	○	TFMOV21R3P241	175	225
		○	○	TFMOV21R2P201	○	○	TFMOV21R3P221	150	200
		○	TFMOV21R2P181	○	○	○	TFMOV21R3P201	140	180
		○	TFMOV21R2P151	○	○	TFMOV21R3P181	○	130	170
	60V	○	TFMOV21R2P121	○	○	TFMOV21R3P151	○	115	150
48V	60V	○	TFMOV21R2P101	○	○	TFMOV21R3P121	○	95	125
	48V	○	TFMOV21R2P820	○	○	TFMOV21R3P101	○	75	100
	36V	○	○	○	○	TFMOV21R3P820	○	60	85
		○	○	○	○	○	○	50	65
		TFMOV21R2P680	○	○	TFMOV21R3P680	○	○	40	56
24V	24V	TFMOV21R2P560	○	○	TFMOV21R3P560	○	○	35	45
		TFMOV21R2P470	○	○	TFMOV21R3P470	○	○	30	38
		○	○	○	○	○	○	25	31
12V	12V	○	○	○	○	○	○	20	26
		○	○	○	○	○	○	17	22

标称放电电流 Nominal Discharge Current I_n (kA)

热保护型压敏电阻 TFMOV

Thermal Fuse & MOV

产品描述 Description

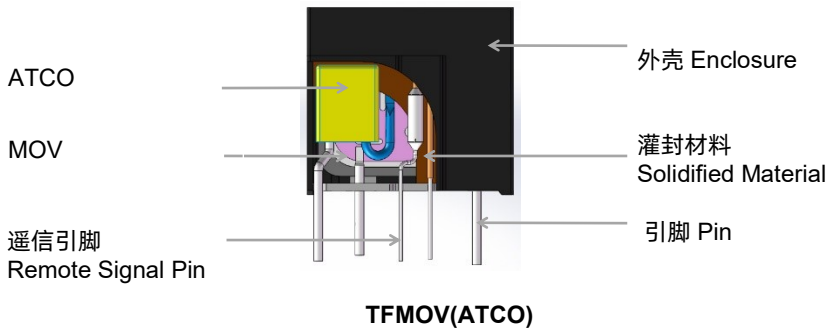
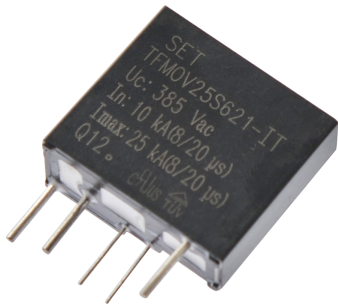

热保护型压敏电阻（TFMOV）是压敏电阻与热保护脱离部件的组合。压敏电阻存在老化特性，热保护型压敏电阻能够在压敏电阻（MOV）劣化或失效时，通过热保护部件的动作将压敏电阻从主回路中脱离。常用于光伏逆变器，通信设备，机房电源等对可靠性和耐候性要求高的场所。

TFMOV is a combination of varistors (MOV) and thermal protection component. Since varistor has the characteristics of aging or degrading; TFMOV can separate the varistor from the main circuitry by opening the thermal protection component when the varistor (MOV) degrades or fails. It is often used in which requires high reliability and weather withstanding, such as photovoltaic inverters, communication equipment, and power supplies in data centers, etc.

电气原理图 Schematics

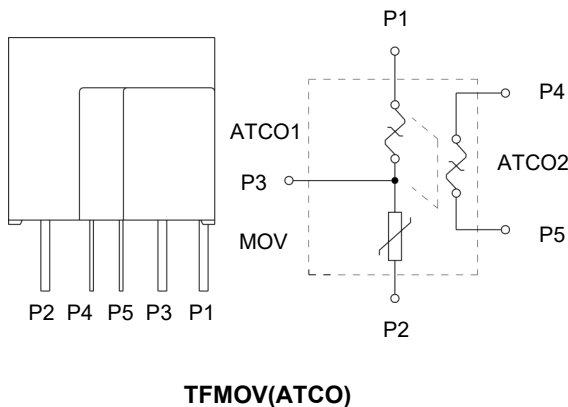

热保护型压敏电阻 TFMOV

Thermal Fuse & MOV

压敏电阻工作原理 MOV Operation Principle

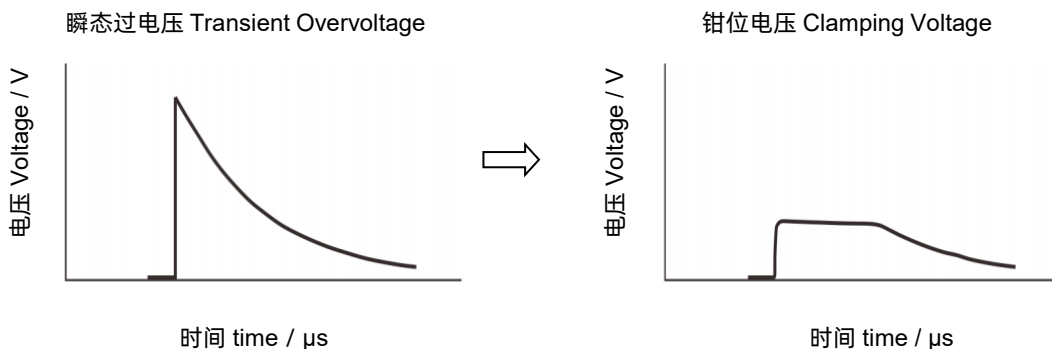

压敏电阻热保护 MOV Thermal Protection

图a为电源常用的电涌保护电路，采用MOV来抑制电涌电压，保护后级电路。由于压敏电阻在劣化或失效时，存在燃烧的风险。在图b高可靠性电涌保护电路中，为了提高电路安全性，采用热保护型压敏电阻TFMOV作为浪涌电压保护元件。热保护型压敏电阻（TFMOV）是压敏电阻与热保护脱离部件的组合。在MOV 温度异常超限时，温度保险丝会先断开，从而使MOV 的失效模式呈现开路失效。

Figure a is a surge protection circuit commonly used in power supplies. MOV is used to suppress the surge voltage and protect the subsequent circuit. There is a risk of burning when the varistor degrades or fails. In the high-reliability surge protection circuit of Figure b, in order to improve the safety of the circuit, a thermal protection varistor TFMOV is used as the surge voltage protection element. TFMOV is a combination of varistors (MOV) and thermal protection component. When the temperature of the MOV is abnormally exceeded, the thermal fuse will be opened first, so that the failure mode of the MOV appears to be open-circuit failure.

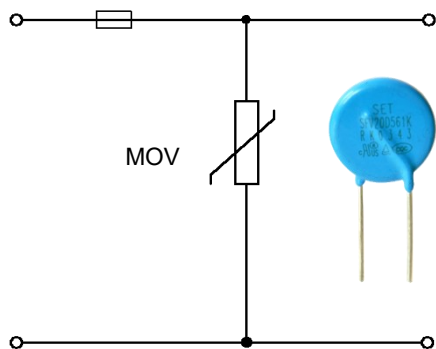

图a 电涌保护典型电路

Figure a Typical surge protection circuit

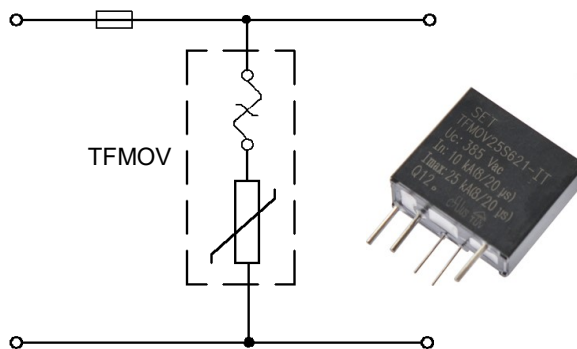

图b 电涌保护高可靠性电路

Figure b: High reliability surge protection circuit

热保护型压敏电阻 TFMOV

Thermal Fuse & MOV

优势 Benefits

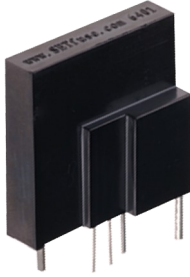

安全 Safety

安全隐患 Hidden Danger

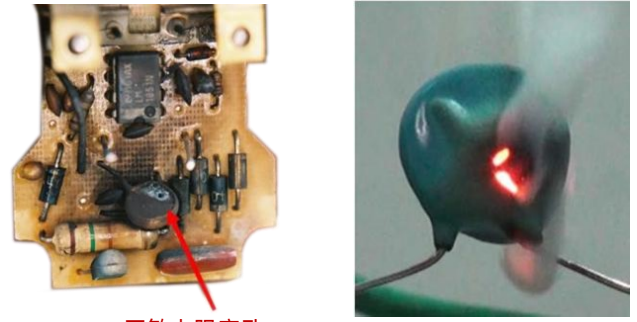
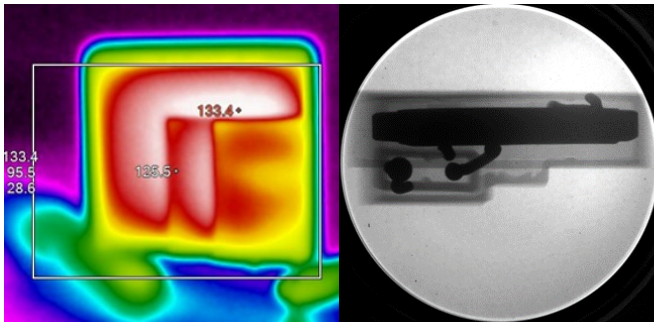

模拟TFMOV劣化失效 TFMOV Failure Simulation

模拟MOV劣化失效 MOV Failure Simulation

TFMOV利用温度保险丝受热熔断的特性，在压敏电阻电性能劣化的过程中，当漏电流才达到数十毫安时，温度保险丝断开，形成如上图所示的开路失效，是可接受的安全失效。

During the electrical performance degrading of varistor, the inbuilt ATCO will open the circuit when the leakage current of varistor increases to tens of micro Amperes. As shown in the figure above, this is a safe open circuit failure.

众所周知，压敏电阻在使用过程中会出现电性能劣化，绝大多数会呈现压敏电压下降、漏电流增加，因热量累积导致温度剧升，使得压敏电阻出现如上图的热击穿而短路失效，存在安全隐患！

The electrical performance of varistor degrades with operating, mostly the varistor voltage drops, and leakage current increases. The heat accumulation can cause the temperature increase sharply and varistor results in thermal breakdown to short circuit status. It's very dangerous.

热保护型压敏电阻 TFMOV

Thermal Fuse & MOV

型号说明 Part Numbering System

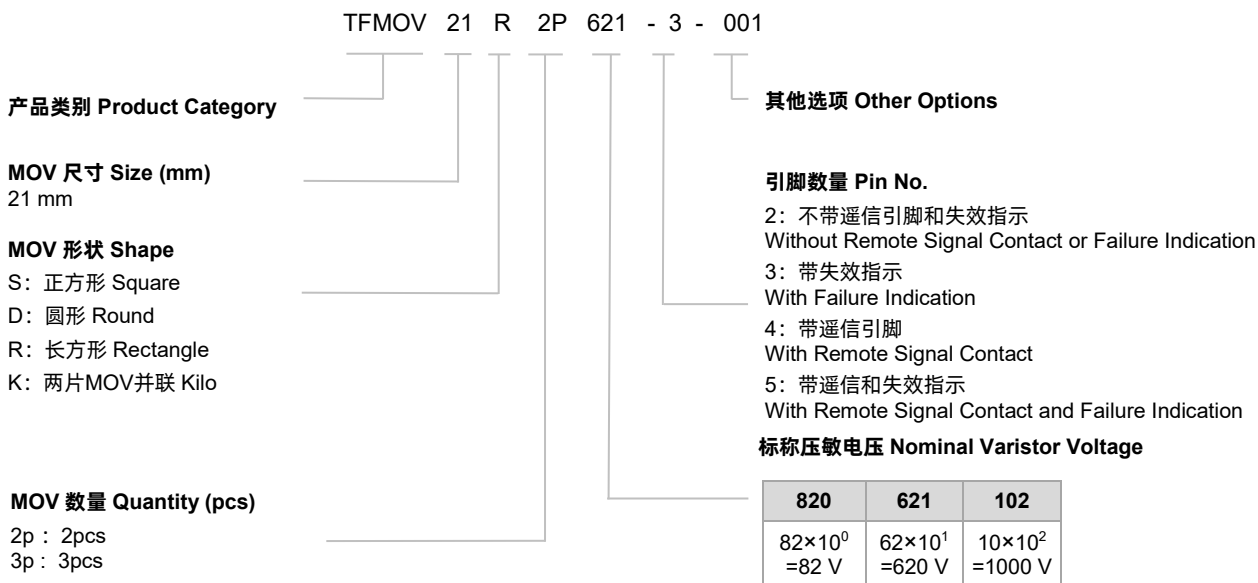

备注 Note:

引脚数量和其他选项仅作为内部唯一规格的认识编码，不作为产品型号一部分。

Pin number and other options are used only as identification codes for internal unique specifications and are not part of the product model

热保护型压敏电阻 TFMOV

Thermal Fuse & MOV

标称放电电流 Nominal Discharge Current

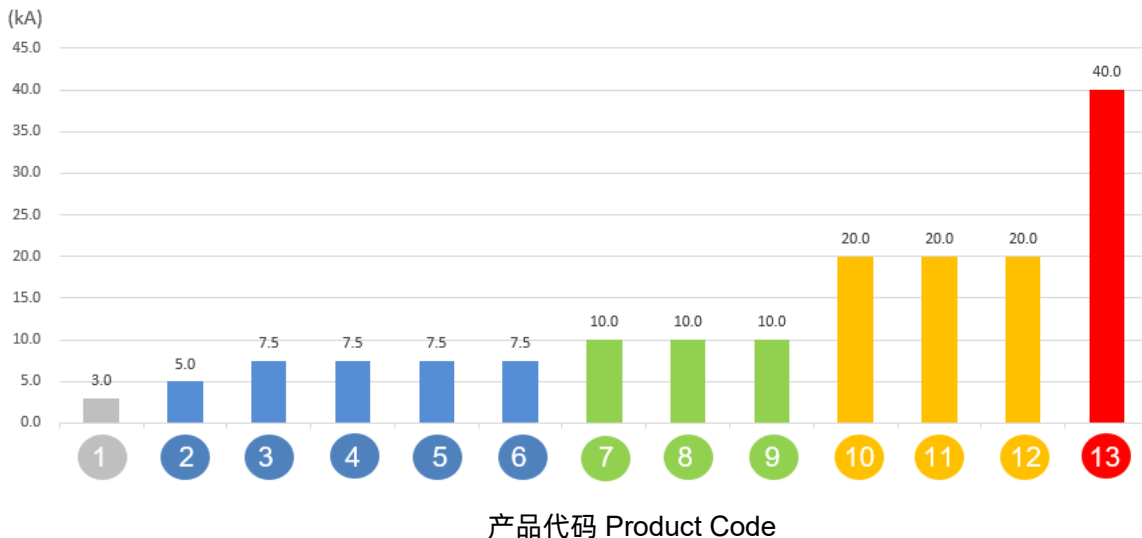

- 1 TFMOV10S Series
- 2 TFMOV15S Series 3 TFMOV20S Series 4 TFMOV20SxxxL Series
- 5 TFMOV21R2P Series 6 TFMOV21R3P Series
- 7 TFMOV25S Series 8 TFMOV25SxxxL Series 9 TFMOV25D Series
- 10 TFMOV34S Series 11 TFMOV34SxxxL Series 12 TFMOV20K Series
- 13 TFMOV40K Series

应用示例 Application Options

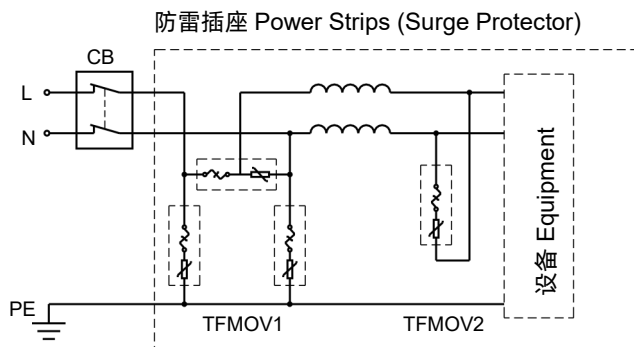
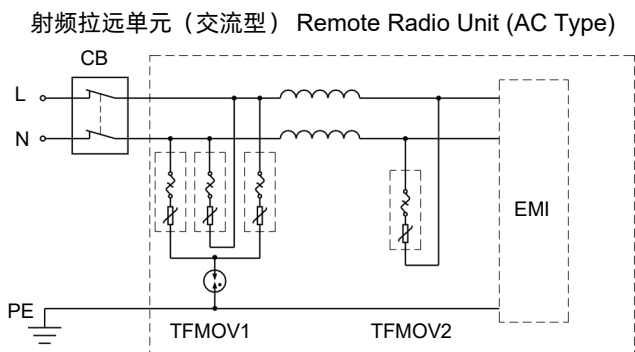

热保护型压敏电阻 TFMOV

Thermal Fuse & MOV

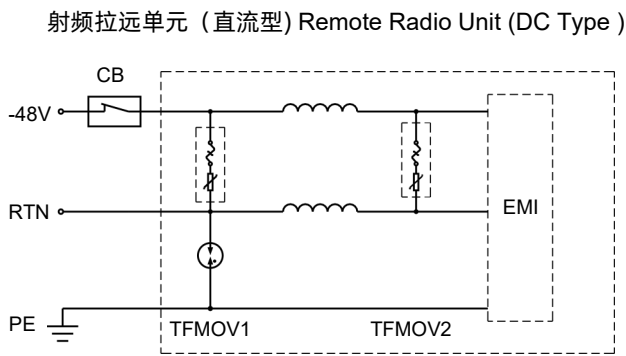
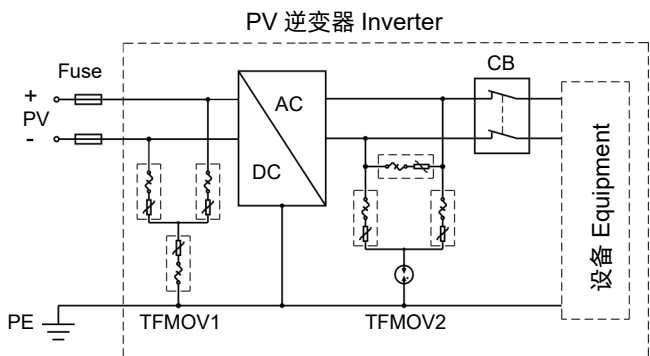

设计 Design

当单一器件的通流容量无法达到设计要求时，通常采用并联的方式满足需求，由于其非线性的电流-电压特性，并联使用过程中应注意以下事项：

1. 需要选用同一厂家，同一型号的压敏电阻进行并联；
2. 需要控制压敏电阻的压敏电压；通常，同一组中间的压敏电压偏差小于1%（最大与最小之间），同时满足下一条；
3. 按平均分配计算的通流容量并留有10%以上的裕量；
4. 设计时需要考虑回路中的浪涌电流均匀分布，如图2。

When a single TFMOV surge capacity can't meet the requirement of customers, paralleling more TFMOVs is recommended.

Due to its nonlinear current-voltage characteristics, please pay attention to below tips:

1. Use the TFMOV from the same manufacturer with same model to parallel.
2. Control the varistor voltage; Typically, the varistor voltage deviation should be less than 1% in the same group (between the Max and Min), and meet the next tip at the same time.
3. Calculate the average surge capacity for each TFMOV and keep a margin at least 10%.
4. Design the layout like Figure.2. to make sure the surge capacity is divided averagely.

错误的设计 The Design not Recommended



图 Figure.1

推荐的设计 The Design Recommended

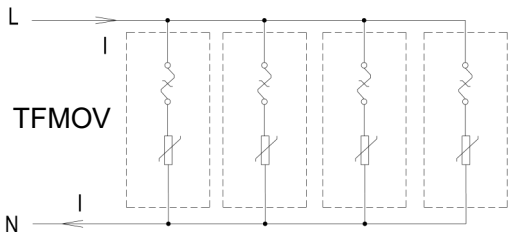

图 Figure.2

热保护型压敏电阻 TFMOV

Thermal Fuse & MOV

认证信息 Agency Information

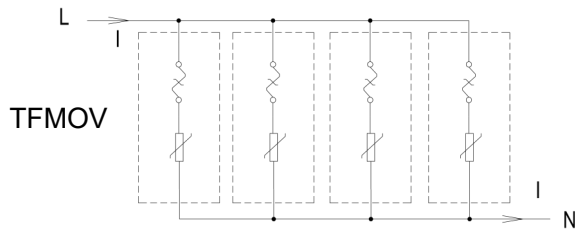
认证信息 Agency Information		标准 Standards	档案号 File NO.	类别 Category
	UL	UL 1449 4th Edition	E322662	VZCA2
	CUL	CSA C22.2 NO.8, CSA ECN 516	E322662	VZCA8
	TUV	EN 61643-11	详见具体型号 See the different models for details	
	CQC	GB 4943.1-2011, GB 8898-2011; GB/T 10193-1997, GB/T 10194-1997	详见具体型号 See the different models for details	

专利 Patents

名称 Name	区域 Region	专利类别 Category	专利号 Patent NO.
设有合金型温度保险丝的压敏电阻 Varistor with In-built Alloy-Type Thermal Fuse	中国 China	发明专利 Patent for Invention	ZL 200510044661.5
一种具有过流过压过温保护功能的电源插座模块 A Protection Pluggable Module with Over Current、Over Voltage、and Over Temperature Protection Function	中国 China	实用新型 Utility Model	ZL 201020244488.X
一种带有双重保护功能的压敏电阻器 A Varistor with Double Protection Function	中国 China	实用新型 Utility Model	ZL 201020255481.8
防雷插座用的防雷模块 Surge Protection Module Applicable for Power Strip	中国 China	实用新型 Utility Model	ZL 201120107173.5
一种防雷插座用的防雷模块 A Surge Protection Module Applicable for Power Strip	中国 China	发明专利 Patent for Invention	ZL 201110092261.7
新型的热保护压敏电阻及浪涌保护器 A New Type of Varistor and Surge Protective Device with Thermal Protection	中国 China	实用新型 Utility Model	ZL 201420306127.1
一种浪涌保护器 A Surge Protective Device	中国 China	实用新型 Utility Model	ZL 201420415059.2
一种热保护压敏电阻及其组合元件 A Varistor and Thermal Protection Component Combination	中国 China	实用新型 Utility Model	ZL 201520376567.9
具合金型温度保险丝的压敏电阻 合金型温度ヒューズ付のバリスタ	日本 Japan	实用新型 Utility Model	3142835
设有合金型温度保险丝的压敏电阻 Varistor with an Alloy-Type Temperature Fuse	澳大利亚 Australia	实用新型 Utility Model	2007100456
具合金型温度保險絲的壓敏電阻 Varistor with an Alloy-Type Temperature Fuse	台湾 Taiwan	实用新型 Utility Model	M 300855
设有合金型温度保险丝的压敏电阻 Varistor with an Alloy-type Temperature Fuse	加拿大 Canada	发明专利 Patent for Invention	2588819
设有合金型温度保险丝的压敏电阻 Metal Oxide Varistor with Built-in Alloy-Type Temperature Fuse	美国 USA	发明专利 Patent for Invention	US 8780521
设有合金型温度保险丝的压敏电阻-带外壳 Varistor with In-built Alloy Type Thermal Fuse (with Housing)	美国 USA	发明专利 Patent for Invention	US 9355763

热保护型压敏电阻 TFMOV

Thermal Fuse & MOV

术语 Glossary

项目 Item	定义 Description
V_N	标称压敏电压 Nominal Varistor Voltage 在特定持续时间的脉冲电流下测得压敏电阻两端的电压。 Voltage, at specified d.c. current used as a reference point in the component characteristic.
8/20 μ s	8/20 冲击电流 Current Impulse 视在波前时间为8 μ s, 半峰值时间为20 μ s的冲击电流。 Current impulse with a nominal virtual front time of 8 μ s and a nominal time to half-value of 20 μ s. — (IEC 61643-11)
1.2/50 μ s	1.2/50 冲击电压 Voltage Impulse 视在波前时间为1.2 μ s, 半峰值时间为50 μ s的冲击电压。 Voltage impulse with a nominal virtual front time of 1.2 μ s and a nominal time to half-value of 50 μ s. — (IEC 61643-11)
U_c	最大持续工作电压 Maximum Continuous Operating Voltage 可连续地施加在SPD上的最大交流电压有效值。 Maximum r.m.s. voltage, which may be continuously applied to the SPD's mode of protection. — (IEC 61643-11)
I_n	标称放电电流 Nominal Discharge Current 流过SPD具有 8/20 波形电流的峰值 Crest value of the current through the SPD having a current waveshape of 8/20. — (IEC 61643-11)
I_{imp}	I 类试验的冲击电流 Impulse Discharge Current for Class I Test I_{imp} 由三个参数来定义: 电流峰值 I_{peak} 、电荷量 Q 和比能量 W/R Crest value of a discharge current through the SPD with specified charge transfer Q and specified energy W/R in the specified time. — (IEC 61643-11)
I_{max}	最大放电电流 Max. Discharge Current 具有 8/20 波形和制造厂声称幅值的流过SPD电流的峰值。 I_{max} 等于或大于 I_n 。 Crest value of a current through the SPD having an 8/20 waveshape and magnitude according to the manufacturers specification. I_{max} is equal to or greater than I_n . — (IEC 61643-11)
V_c	钳位电压 Clamping Voltage 在标准大气压环境下, 压敏电阻中流过 8/20 等级电流脉冲时, 压敏电阻两端呈现的电压峰值。 Peak voltage developed across the varistor terminations under standard atmospheric conditions, when passing an 8/20 class current pulse.
C_v	电容量 Capacitance 特定频率和电压下压敏电阻两端测得的电容量。 Capacitance across the MOV measured at a specified frequency and voltage.

热保护型压敏电阻 TFMOV

Thermal Fuse & MOV

术语 Glossary

项目 Item	定义 Description
Modes of protection	<p>保护模式 Modes of protection</p> <p>在端子间包含保护元件的电流路径，例如相对相、相对地、相对中线、中线对地。 An intended current path, between terminals that contains protective components, e.g. line-to-line, line-to-earth, line-to-neutral, neutral-to-earth.</p> <p style="text-align: right;">— (IEC 61643-11)</p>
TCO	<p>热熔断体 Thermal-Link</p> <p>装有温感元件的不可复位器件，当它暴露在高于设定温度达到一定时间就会将电路断开。 A non-resettable device incorporating a THERMAL ELEMENT which will open a circuit once only when exposed for a sufficient length of time to a temperature in excess of that for which it has been designed.</p>
ATCO	<p>合金热熔断体 Alloy Thermal-Link</p> <p>温感元件由合金材料制作的热熔断体。 Alloy Type Thermal-Link, Alloy is the thermal element.</p>

TFMOV

TFMOV

热保护型压敏电阻 TFMOV

Thermal Fuse & MOV



注意 ATTENTION

使用方法 Usage

1. 交流频率在47 Hz和63 Hz之间。
Frequency range is from 47 Hz to 63 Hz a.c.
2. 持续施加在热保护型压敏电阻上的电压不应超过其最大连续工作电压 U_c 。
The voltage applied continuously to the TFMOV can not exceed its maximum continuous operating voltage U_c .
3. 气压在80 kPa 到106 kPa, 对应海拔为+2000 m至- 500 m。
When atmosphere press is from 80 kPa to 106 kPa, the related altitude shall be from +2000 m to -500 m.
4. 通电情况下请勿直接触碰本体或引脚, 防止触电。
Do not touch the product body or pins directly when power is on, to avoid electric shock.
5. 请不要用酮类、酯类、苯类、卤代烃等极性溶剂清洗本产品, 以免破坏产品的封装层。
Do not clean the TFMOV with strong polar solvent such as ketone, esters, benzene, halogenated hydrocarbon, to avoid damaging the encapsulating layer.
6. 应用本产品的设备必须有可靠的接地线与大地相连。
It should have a reliable grounding when using these products.

更换 Replacement

基于安全原因, 热保护型压敏电阻是不可修复的产品, 替换时应使用同类别同型号的产品。
TFMOV is a non-repairable product. For safety sake, please use equivalent TFMOV for replacement.

存贮 Storage

热保护型压敏电阻的存贮应避免高温、高湿、日光直射和腐蚀性气体的场合, 避免影响引脚可焊性, 产品购入后请于1年内使用完。
Do not store TFMOV at high temperature, high humidity or corrosive gas environment. To avoid reducing the solderability of the pins, please use them up within 1 year after receiving the goods.

安装位置 Installation Position

勿将热保护型压敏电阻安装在可能经常出现剧烈振动的地方。
Do not install the TFMOV on a place that may often suffer severe continuous vibration.

热保护型压敏电阻 TFMOV

Thermal Fuse & MOV

机械应力 Mechanical Stress

装配时应避免出现如敲击等作业方式，避免造成产品出现机械损伤。

Do not take violent action such as knocking when assembling to avoid mechanical damage.

波峰焊参数 (参考) Wave Soldering Parameters (For Reference Only)

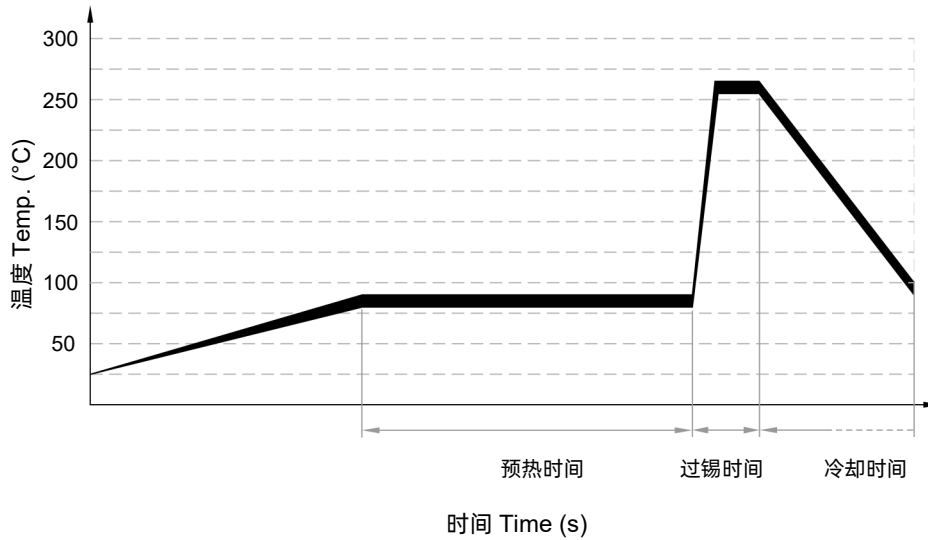

项目 Items	温度 Temp. (°C)	时间 Time (s)
预热 Preheating	80 to 90	60 to 150
过锡 Dwelling	250 to 260	2 to 4

推荐的手工焊参数 Recommended Hand-Soldering Parameters

项目 Item	条件 Condition
烙铁头温度 Iron Temperature	350 °C (Max.)
焊接时间 Soldering Time	4 seconds (Max.)
焊接点距产品底部的距离 Distance between Soldering Point and the Bottom of Product	2 mm (Min.)

热保护型压敏电阻 TFMOV

Thermal Fuse & MOV

TFMOV21R2P 系列 Series

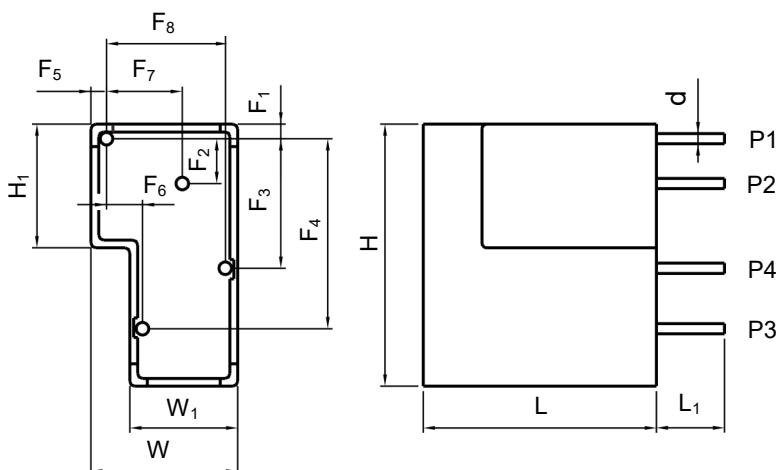
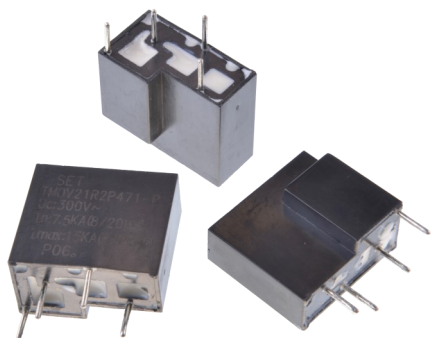

备注 Note: 单位 Unit: mm

标称压敏电压 Nominal Varistor Voltage	L (±1.0)	L ₁ (±1.0)	W (±1.0)	W ₁ (±1.0)	H (±1.0)	H ₁ (±0.5)	d (-0.05,+0.15)	F ₁ (±0.5)
470 - 271	24.0	7.0	13.3	9.3	26.9	12.7	1.05	1.5
301 - 511	24.0	7.0	15.1	11.1	26.9	12.7	1.05	1.5
标称压敏电压 Nominal Varistor Voltage	F ₂ (±0.5)	F ₃ (±0.5)	F ₄ (±0.5)	F ₅ (±0.5)	F ₆ (±0.5)	F ₇ (±0.5)	F ₈ (±0.5)	
470 - 271	4.6	13.3	19.5	1.6	4.5	6.7	9.6	
301 - 511	4.6	13.3	19.5	1.6	3.7	7.8	12.6	

安规认证 Agency Approvals

机构 Agency	标准 Standards	档案号 No.
UL	UL1449	E322662
CQC	GB 4943.1-2011 GB 8898-2011	CQC15001125795
环境 Environment	RoHS & REACH	符合 Compliant

电气原理图 Schematics

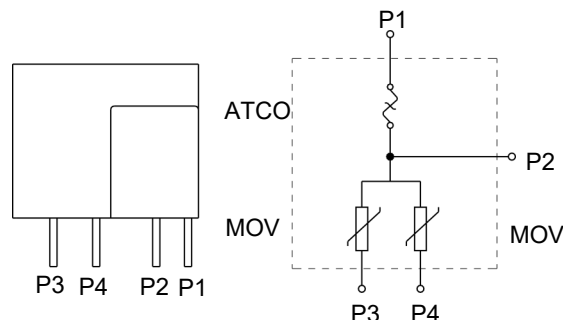

包装信息 Packaging Information

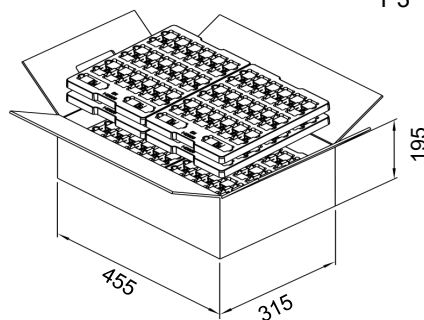
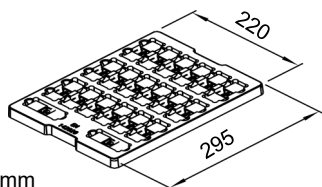

单位 Unit: mm

有特殊包装需求请联系我们

Please contact us if you have special packaging requirements.

项目 Item	标称压敏电压 Nominal Varistor Voltage	托 Tray	箱 Carton
尺寸 Dimensions (mm)	N/A	295 × 220	455 × 315 × 195
数量 Quantity (PCS)	470 - 271	40	800
	301 - 511	40	640

技术参数 Specifications

型号 Model	最大连续工作电压 Max. Continuous Operating Voltage		压敏电压 Varistor Voltage @1 mA DC		钳位电压 Clamping Voltage (Max.)		标称放电 电流 Nominal Discharge Current (8/20 μs)	最大放电 电流 Max. Discharge Current (8/20 μs)	限压比 Voltage Clamping Ratio ^a		最大能量 (焦耳) Max. Energy (Joule)	静态电容 (参考) Typical Capacitance (Reference)	温度保险丝 Thermal Fuse
	U _c		Min.	Max.	V _C	I _P	I _n	I _{max}	R _{cl}	I _n	10/1000 μs	@1 kHz	UL 60691
	(VAC)	(VDC)	(V)		(V)	(A)	(kA)			(kA)	(J)	(pF)	
TFMOV21R2P470	30	38	42	52	93	25	2.5×2	5×2	4.3	2.5	41×2	8880×2	VT 系列 Series U _r :690 VAC I _r :15 A / 16 A
TFMOV21R2P560	35	45	50	62	110	25	2.5×2	5×2	3.8	2.5	49×2	7800×2	
TFMOV21R2P680	40	56	61	75	135	25	2.5×2	5×2	3.8	2.5	59×2	7000×2	
TFMOV21R2P820	50	65	74	90	135	115	5×2	10×2	3.2	5	67×2	5880×2	
TFMOV21R2P101	60	85	90	110	165	115	5×2	10×2	3.2	5	84×2	4800×2	
TFMOV21R2P121	75	100	108	132	200	115	5×2	10×2	3.2	5	102×2	4000×2	
TFMOV21R2P151	95	125	135	165	250	115	5×2	10×2	3.2	5	127×2	3200×2	
TFMOV21R2P181	115	150	162	198	300	115	5×2	10×2	2.3	5	156×2	2650×2	
TFMOV21R2P201	130	170	185	225	340	115	7.5×2	15×2	2.3	7.5	170×2	2400×2	
TFMOV21R2P221	140	180	198	242	360	115	7.5×2	15×2	2.3	7.5	185×2	2160×2	
TFMOV21R2P241	150	200	216	264	395	115	7.5×2	15×2	2.3	7.5	200×2	2000×2	
TFMOV21R2P271	175	225	243	297	455	115	7.5×2	15×2	2.3	7.5	230×2	1800×2	
TFMOV21R2P301	190	250	270	330	500	115	7.5×2	15×2	2.3	7.5	250×2	1560×2	
TFMOV21R2P331	210	275	297	363	550	115	7.5×2	15×2	2.3	7.5	270×2	1440×2	
TFMOV21R2P361	230	300	324	396	595	115	7.5×2	15×2	2.3	7.5	305×2	1320×2	
TFMOV21R2P391	250	320	351	429	650	115	7.5×2	15×2	2.3	7.5	330×2	1200×2	
TFMOV21R2P431	275	350	387	473	710	115	7.5×2	15×2	2.3	7.5	365×2	1160×2	
TFMOV21R2P471	300	385	423	517	775	115	7.5×2	15×2	2.3	7.5	420×2	1020×2	
TFMOV21R2P511	320	415	459	561	845	115	7.5×2	15×2	2.3	7.5	430×2	935×2	

备注 Note:

a: $R_{cl} = \frac{V_C}{I_n}$, $U_p \geq V_C$, V_C : 钳位电压 (@ I_n), V_N : 压敏电压, U_p : 电压保护水平; 电压保护水平 (U_p) 根据计算结果按 IEC 61643-11:2011 6.4条款优选值选定; 电压保护水平优选值(kV): 0.08, 0.09, 0.10, 0.12, 0.15, 0.22, 0.33, 0.4, 0.5, 0.6, 0.7, 0.8, 0.9, 1.0, 1.2, 1.5, 1.8, 2.0, 2.5, 3.0, 4.0, 5.0, 6.0, 8.0, 10.

a: $R_{cl} = \frac{V_C}{I_n}$, $U_p \geq V_C$, V_C : Clamping Voltage (@ I_n), V_N : Varistor Voltage, U_p : Voltage Protection Level.

The Value of Voltage Protection Level (U_p) is determined according to IEC 61643-11:2011 clause 6.4. Preferred values of voltage protection level (kV): 0.08, 0.09, 0.10, 0.12, 0.15, 0.22, 0.33, 0.4, 0.5, 0.6, 0.7, 0.8, 0.9, 1.0, 1.2, 1.5, 1.8, 2.0, 2.5, 3.0, 4.0, 5.0, 6.0, 8.0, 10.

性能曲线 Performance Curve

受限电流测试曲线 (UL 1449 4th 44.4章) Limited Current Test Curve (UL 1449 4th clause 44.4)

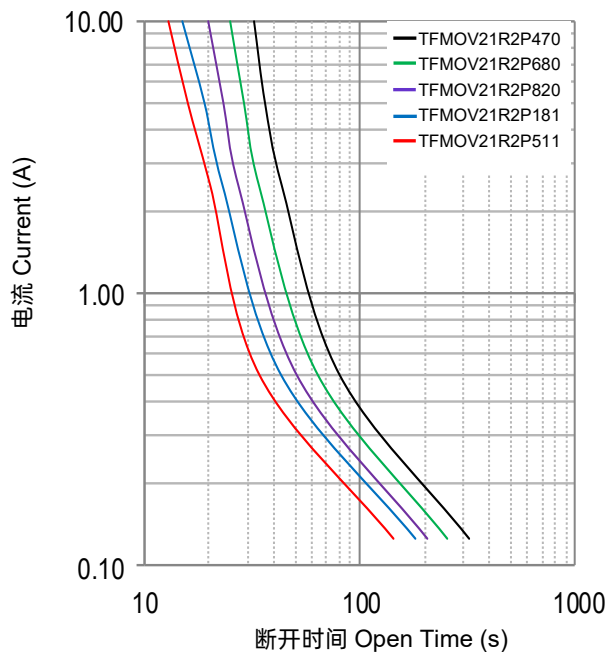

备注: 受限电流测试曲线仅供参考 Note: The limited current test curve is for reference only.

冲击电流降额曲线 Max. Peak Current Derating Curve

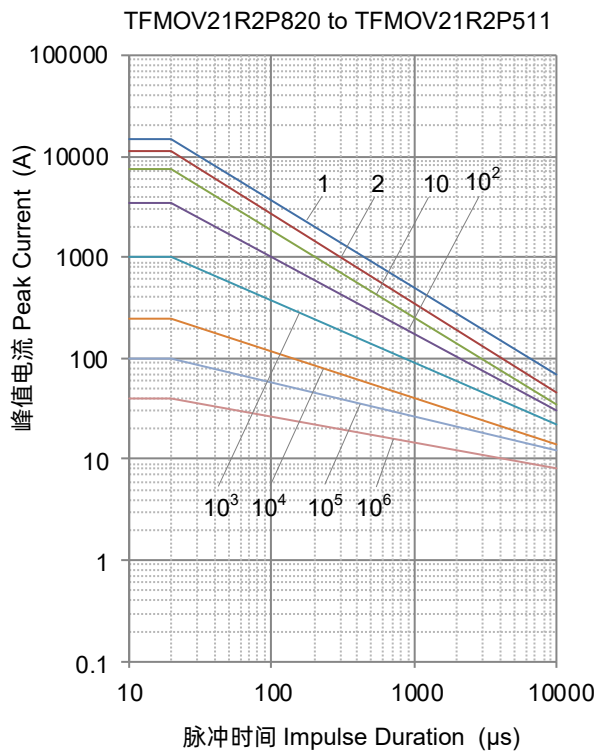
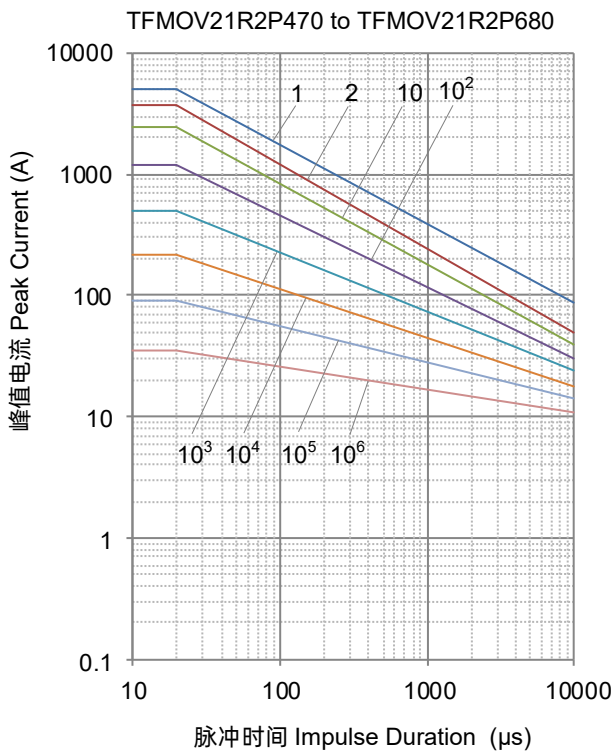

备注 Note: 1, 2, 10, 10², 10³, 10⁴, 10⁵, 10⁶ 代表重复次数 Stand for number of repetitions.

伏安特性曲线 Voltage-Current Characteristic Curves

