

TVS Diodes

Transient Voltage Suppression Diodes



TVS

TVS

Description

Transient Voltage Suppressor (TVS) is a circuit protection component that either attenuates (reduces) or filters a transient voltage spike (overvoltage), TVS diodes provide critical protection by going into avalanche breakdown within no more than a few nanoseconds after a strike, clamping the transient voltage, and routing its current to the ground.

Applications

- Communication Equipment
- Security & Protection
- Industrial Control Equipment
- Power Supply
- Automotive Electronics
- New Energy
- Lightning Protection

Functional Diagram

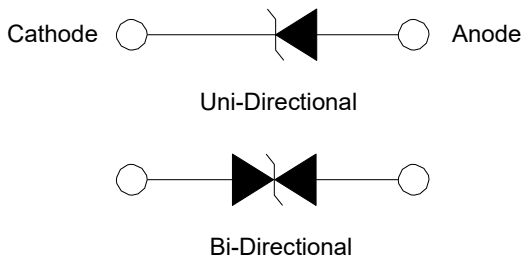

Features

- Meet AEC-Q101 requirement
- Low incremental surge resistance
- Excellent clamping capability
- Low profile package with built-in strain relief
- 3000 W peak pulse power capability with a 10/1000 μS Waveform, repetition rate (duty cycle): 0.01%
- For surface mounted applications to optimize board space
- Typical failure mode is short from over-specified voltage or current
- IEC 61000-4-2 ESD 30 kV (Air), 30 kV (Contact)
- EFT protection of data lines in accordance with IEC 61000 -4-4
- Very fast response time
- Glass passivated chip junction
- High temperature to reflow soldering guaranteed: 260 °C/30sec
- $V_{BR} @ T_J = V_{BR@25\text{ °C}} \times (1 + \alpha T \times (T_J - 25))$
(αT : Temperature Coefficient, typical value is 0.1%)
- Plastic package is flammability rated V-0 per Underwriters Laboratories
- Meet MSL level1, per J-STD-020
- Matte tin lead-free plated
- Halogen free and RoHS compliant
- Pb-free E3 means 2nd level interconnect is Pb-free and the terminal finish material is tin(Sn) (IPC/JEDEC J-STD-609A.01)

Package Outline Dimensions (DO-214AB)

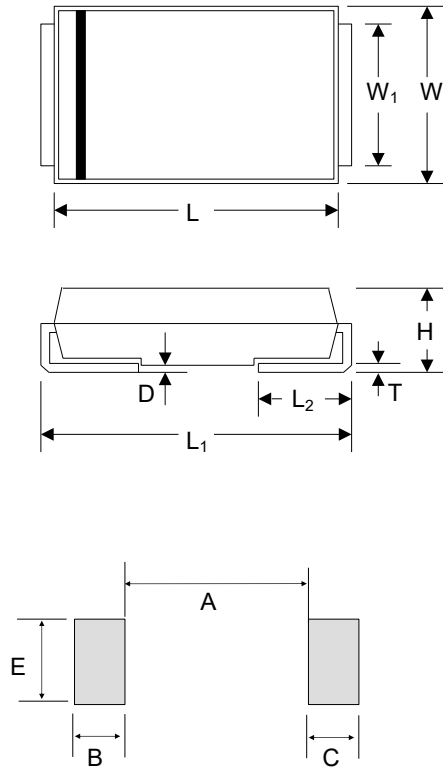

Mounting Pad Layout

Symbol	Millimeters		Inches	
	Min.	Max.	Min.	Max.
L	6.60	7.11	0.260	0.280
W	5.59	6.22	0.220	0.245
W ₁	2.90	3.20	0.114	0.126
H	2.06	2.62	0.079	0.103
T	0.152	0.305	0.006	0.012
L ₁	7.75	8.13	0.305	0.320
L ₂	0.76	1.52	0.030	0.060
D	-	0.203	-	0.008
A	-	4.200	-	0.165
B	2.4	-	0.094	-
C	2.40	-	0.094	-
E	3.30	-	0.129	-

TVS

TVS

Maximum Ratings and Characteristics

(Ratings at 25 °C ambient temperature unless otherwise specified.)

Parameter	Symbol	Value	Unit
Peak Power Dissipation(Fig.2)- with a 10/1000 μS waveform(Fig.4)	P _{PPM}	3000	W
Peak Power Dissipation on Infinite Heat Sink at T _L =50 °C	P _D	6.5	W
Peak Forward Surge Current,8.3 ms single half sinewave superimposed on rated load (JEDEC Method) ⁽¹⁾	I _{FSM}	200	A
Maximum Instantaneous Forward Voltage at 100 A for Unidirectional Only	V _F	3.5	V
Operating Temperature Range	T _J	-65 to 150	°C
Storage Temperature Range	T _{STG}	-65 to 175	°C
Typical Thermal Resistance Junction to Lead	R _{θJL}	15	°C / W
Typical Thermal Resistance Junction to Ambient	R _{θJA}	75	°C / W

Note

1.Measured of 8.3 ms single half sine-wave or equivalent square wave, duty cycle=4 pulses per minute maximum.

Part Numbering System

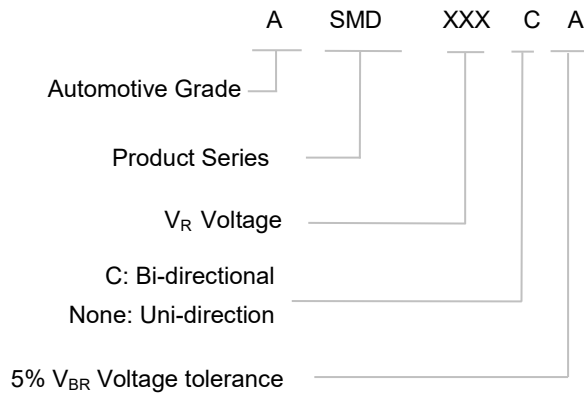

Marking

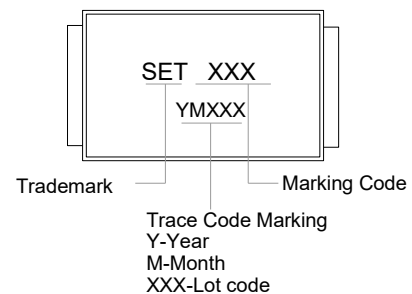
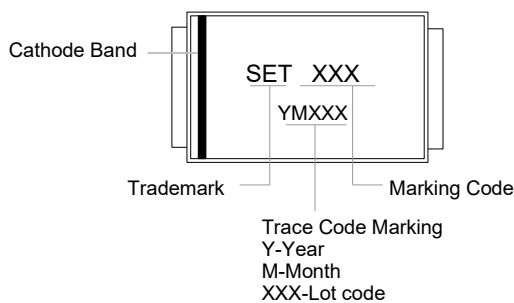

Glossary

Item	Description
V_C	Clamping Voltage Voltage across TVS in a region of low differential resistance that serves to limit the voltage across the device terminals.
V_R	Reverse Stand-off Voltage Maximum voltage that can be applied to the TVS without operation. NOTE : It is also shown as V_{WM} (maximum working voltage (maximum d.c. voltage)) and known as rated stand-off voltage (V_{so}).
I_R	Reverse Leakage Current Current measured at V_R . NOTE : Also shown as I_D for stand-by current.
V_{BR}	Breakdown Voltage Voltage across TVS at a specified current I_T in the breakdown region.
I_{PPM}	Rated Random Recurring Peak Impulse Current Maximum-rated value of random recurring peak impulse current that may be applied to a device.
$P_{M(AV)}$	Rated Average Power Dissipation Maximum-rated value of power dissipation resulting from all sources, including transients and standby current, averaged over a short period of time.
P_{PPM}	Rated Random Recurring Peak Impulse Power Dissipation Maximum-rated value of the product of rated random recurring peak impulse current (I_{PPM}) multiplies by specified maximum clamping voltage (V_C).
C_J	Capacitance Capacitance across the TVS measured at a specified frequency and voltage.
V_{FS}	Peak Forward Surge Voltage Peak voltage across an TVS for a specified forward surge current (I_{FS}) and time duration. NOTE : Also shown as V_F .
I_{FS}	Forward Surge Current Pulsed current through TVS in the forward conducting region. NOTE : Also shown as I_F .
$\alpha_{V(BR)}$	Temperature Coefficient of Breakdown Voltage The change of breakdown voltage divided by the change of temperature.
I_{PP}	Peak pulse Current Peak pulse current value applied across the TVS to determine the clamping voltage V_C for a specified wave shape.
I_T	Pulsed D.C. Test Current Test current for measurement of the breakdown voltage V_{BR} . This is defined by the manufacturer and usually given in milliamperes with a pulse duration of less than 40 ms. NOTE : Also shown as I_{BR} .

—(GB-T 18802.321 / IEC 61643-321 / JESD210A)

Electrical Characteristics (T_A=25 °C unless otherwise noted)Table 1

Part Number		Device Marking Code		Breakdown Voltage V _{BR} @I _T		Test Current I _T	Reverse Stand-off Voltage V _R	Max. Reverse Leakage I _R @V _R	Max. Peak Pulse Current I _{PPM}	Max. Clamping Voltage V _C @I _{PPM}
Uni	Bi	Uni	Bi	Min	Max					
				(V)		(mA)	(V)	(µA)	(A)	(V)
ASMD5.0A	ASMD5.0CA	ACAE	ACWE	6.4	7.07	10	5	1000	326.1	9.2
ASMD6.0A	ASMD6.0CA	ACAG	ACWG	6.67	7.37	10	6	1000	291.3	10.3
ASMD6.5A	ASMD6.5CA	ACAK	ACWK	7.22	7.98	10	6.5	500	267.9	11.2
ASMD6.8A	ASMD6.8CA	ACEE	ACFE	7.56	8.35	10	6.8	500	250	12
ASMD7.0A	ASMD7.0CA	ACAM	ACWM	7.78	8.6	10	7	200	250	12
ASMD7.5A	ASMD7.5CA	ACAP	ACWP	8.33	9.21	1	7.5	100	232.6	12.9
ASMD8.0A	ASMD8.0CA	ACAR	ACWR	8.89	9.83	1	8	50	220.6	13.6
ASMD8.5A	ASMD8.5CA	ACAT	ACWT	9.44	10.4	1	8.5	20	208.3	14.4
ASMD9.0A	ASMD9.0CA	ACAV	ACWV	10	11.1	1	9	10	194.8	15.4
ASMD10A	ASMD10CA	ACAX	ACWX	11.1	12.3	1	10	3	176.5	17
ASMD11A	ASMD11CA	ACAZ	ACWZ	12.2	13.5	1	11	3	164.8	18.2
ASMD12A	ASMD12CA	ACBE	ACXE	13.3	14.7	1	12	3	150.8	19.9
ASMD13A	ASMD13CA	ACBG	ACXG	14.4	15.9	1	13	3	139.5	21.5
ASMD14A	ASMD14CA	ACBK	ACXK	15.6	17.2	1	14	3	129.3	23.2
ASMD15A	ASMD15CA	ACBM	ACXM	16.7	18.5	1	15	3	123	24.4
ASMD16A	ASMD16CA	ACBP	ACXP	17.8	19.7	1	16	3	115.4	26
ASMD17A	ASMD17CA	ACBR	ACXR	18.9	20.9	1	17	3	108.7	27.6
ASMD18A	ASMD18CA	ACBT	ACXT	20	22.1	1	18	3	102.7	29.2
ASMD20A	ASMD20CA	ACBV	ACXV	22.2	24.5	1	20	3	92.6	32.4
ASMD22A	ASMD22CA	ACBX	ACXX	24.4	26.9	1	22	3	84.5	35.5
ASMD24A	ASMD24CA	ACBZ	ACXZ	26.7	29.5	1	24	3	77.1	38.9
ASMD26A	ASMD26CA	ACCE	ACYE	28.9	31.9	1	26	3	71.3	42.1
ASMD28A	ASMD28CA	ACCG	ACYG	31.1	34.4	1	28	3	66.1	45.4
ASMD30A	ASMD30CA	ACCK	ACYK	33.3	36.8	1	30	3	62	48.4
ASMD33A	ASMD33CA	ACCM	ACYM	36.7	40.6	1	33	3	56.3	53.3
ASMD36A	ASMD36CA	ACCP	ACYP	40	44.2	1	36	3	51.6	58.1
ASMD40A	ASMD40CA	ACCR	ACYR	44.4	49.1	1	40	3	46.5	64.5
ASMD43A	ASMD43CA	ACCT	ACYT	47.8	52.8	1	43	3	43.2	69.4
ASMD45A	ASMD45CA	ACCV	ACYV	50	55.3	1	45	3	41.3	72.7
ASMD48A	ASMD48CA	ACCX	ACYX	53.3	58.9	1	48	3	38.8	77.4
ASMD51A	ASMD51CA	ACCZ	ACYZ	56.7	62.7	1	51	3	36.4	82.4
ASMD54A	ASMD54CA	ACRE	ACZE	60	66.3	1	54	3	34.4	87.1

TVS

TVS

TVS Diodes

Transient Voltage Suppression Diodes

ASMD Series

Part Number		Device Marking Code		Breakdown Voltage $V_{BR}@I_T$		Test Current I_T	Reverse Stand-off Voltage V_R	Max. Reverse Leakage $I_R@V_R$	Max. Peak Pulse Current I_{PPM}	Max. Clamping Voltage $V_C@I_{PPM}$
				Min	Max					
Uni	Bi	Uni	Bi	(V)		(mA)	(V)	(μ A)	(A)	(V)
ASMD58A	ASMD58CA	ACRG	ACZG	64.4	71.2	1	58	3	32.1	93.6
ASMD60A	ASMD60CA	ACRK	ACZK	66.7	73.7	1	60	3	31	96.8
ASMD64A	ASMD64CA	ACRP	ACZP	71.1	78.6	1	64	3	29.1	103
ASMD68A	ASMD68CA	ACRC	ACZC	75.5	83.5	1	68	3	27.5	109
ASMD70A	ASMD70CA	ACEK	ACFK	77.8	86	1	75	3	26.5	113
ASMD75A	ASMD75CA	ACRR	ACZR	83.3	92.1	1	78	3	24.8	121
ASMD78A	ASMD78CA	ACRT	ACZT	86.7	95.8	1	78	3	23.8	126
ASMD85A	ASMD85CA	ACRV	ACZV	94.4	104	1	85	3	21.9	137
ASMD90A	ASMD90CA	ACRX	ACZX	100	111	1	90	3	20.5	146
ASMD100A	ASMD100CA	ACRZ	ACZZ	111	123	1	100	3	18.5	162
ASMD110A	ASMD110CA	ACSE	ACVE	122	135	1	110	3	16.9	177
ASMD120A	ASMD120CA	ACSG	ACVG	133	147	1	120	3	15.5	193
ASMD130A	ASMD130CA	ACSK	ACVK	144	159	1	130	3	14.4	209
ASMD150A	ASMD150CA	ACSM	ACVM	167	185	1	150	3	12.3	243
ASMD160A	ASMD160CA	ACSP	ACVP	178	197	1	160	3	11.6	259
ASMD170A	ASMD170CA	ACSR	ACVR	189	209	1	170	3	10.9	275
ASMD188A	ASMD188CA	ACSS	ACVS	209	231	1	188	3	9.1	328
ASMD200A	ASMD200CA	ACSV	ACVV	222	246	1	200	3	9.3	323
ASMD220A	ASMD220CA	ACSX	ACVX	245	270	1	220	3	8.5	355
ASMD240A	ASMD240CA	ACSZ	ACVZ	267	295	1	240	3	7.7	388
ASMD250A	ASMD250CA	ACTT	ACUT	278	307	1	250	3	7.4	404
ASMD300A	ASMD300CA	ACTG	ACUG	333	368	1	300	3	6.2	485
ASMD350A	ASMD350CA	ACTR	ACUR	389	429	1	350	3	5.3	566
ASMD360A	ASMD360CA	ACTK	ACUK	400	442	1	360	3	5.2	582
ASMD400A	ASMD400CA	ACTM	ACUM	445	491	1	400	3	4.6	646
ASMD440A	ASMD440CA	ACTP	ACUP	489	540	1	440	3	4.2	711

Notes:

1. For bidirectional type having V_R of 10 volts and less, the I_R should be doubled.
2. For parts without A in the PN, the V_{BR} tolerance is $\pm 10\%$ and V_C is 5% higher than parts with A. The parts without A are currently available, but not recommended for new designs. The parts with A are preferred.

TVS

TVS

TVS Diodes

Transient Voltage Suppression Diodes

I-V Curve Characteristics

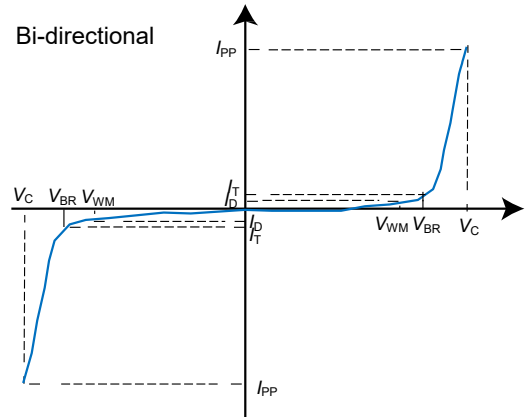
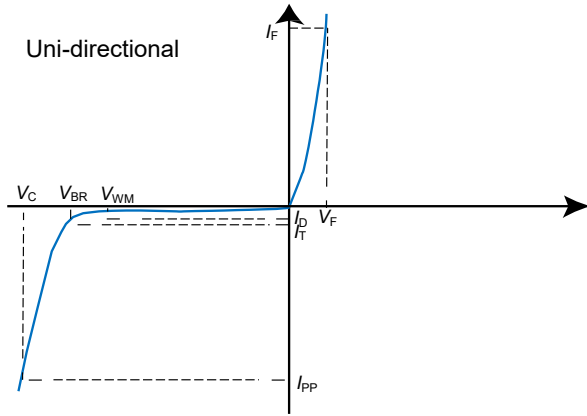

Performance Curve for Reference ($T_A=25^\circ\text{C}$ unless otherwise noted)

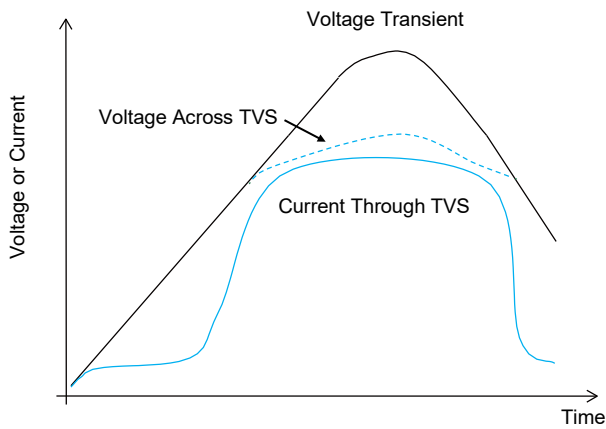

FIGURE 1 TVS Transients Clamping Waveform

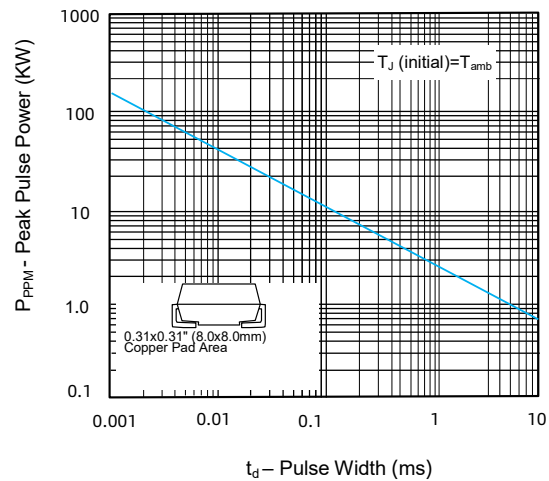

FIGURE 2 Peak Pulse Power Rating Curve

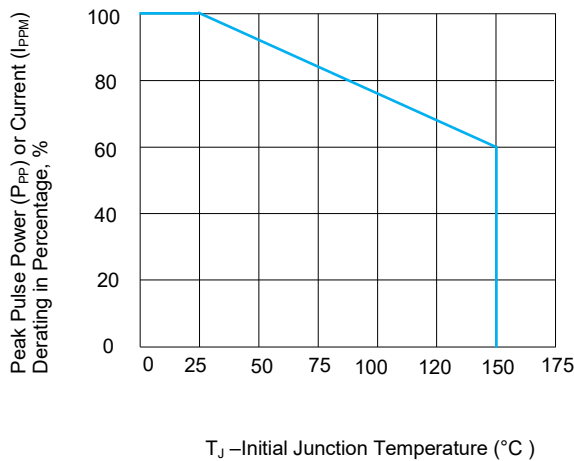

FIGURE 3 Peak Pulse Power Derating Curve

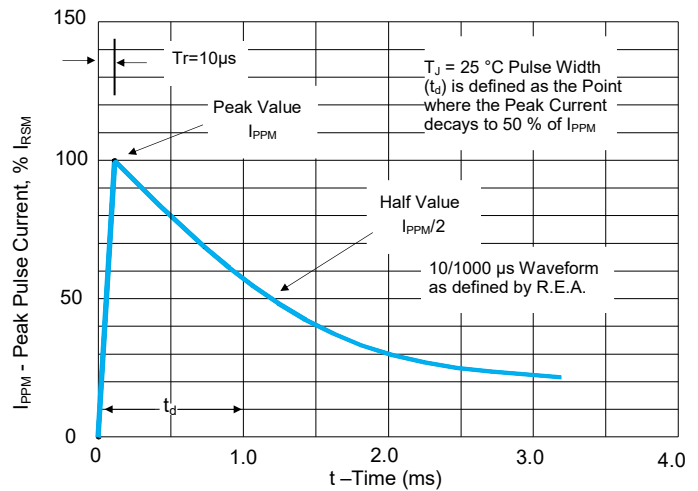

FIGURE 4 Pulse Waveform

TVS Diodes

Transient Voltage Suppression Diodes

ASMD Series

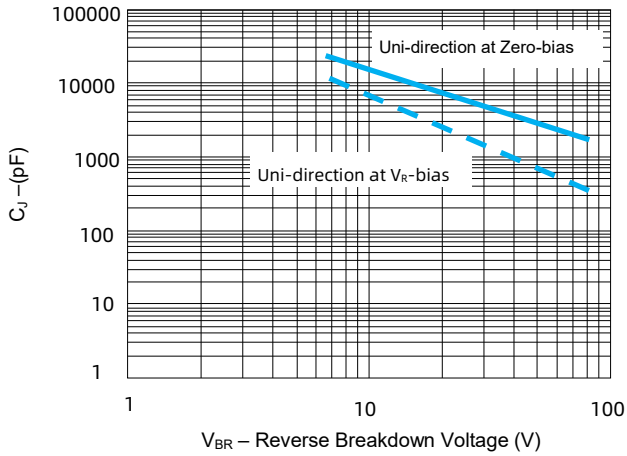

FIGURE 5 Typical Junction Capacitance

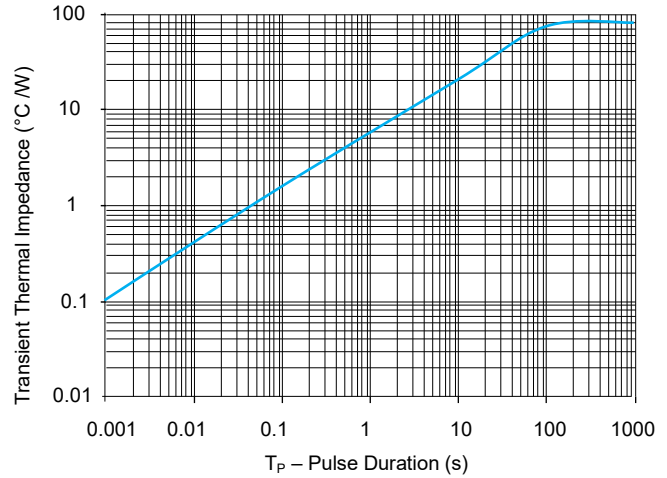

FIGURE 6 Typical Transient Thermal Impedance

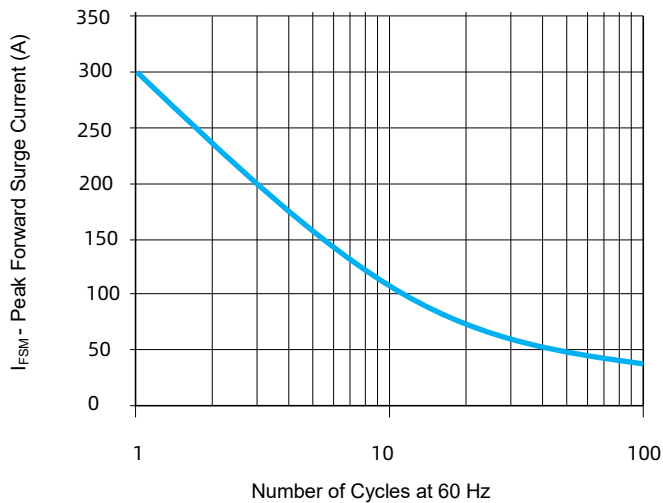

FIGURE 7 Maximum Non-Repetitive Forward Surge Current Uni-Directional only

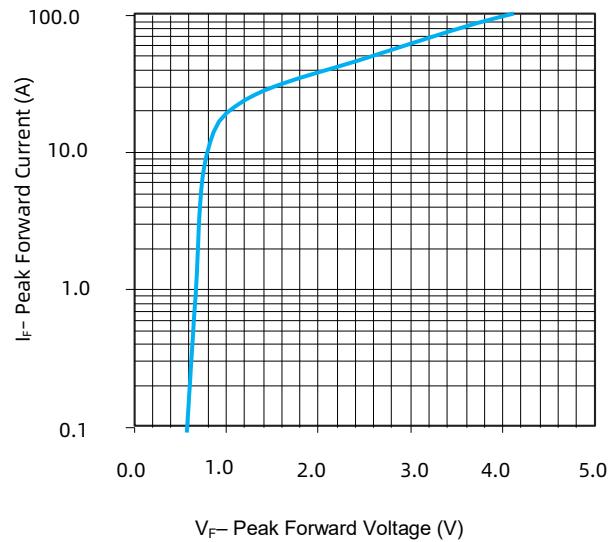

FIGURE 8 Peak Forward Drop vs Peak Forward Current (Typical Values)

Environmental Specifications

High Temp. Storage	JESD22-A103
HTRB	JESD22-A108
Temperature Cycling	JESD22-A104
MSL	JESDEC-J-STD-020, Level 1
H3TRB	JESD22-A101
RSH	JESD22-A111

Physical Specifications

Weight	0.007 ounce, 0.21 grams
Case	JESD22DO214AB. Molded plastic body over glass passivated junction
Polarity	Color band denotes positive end (cathode) except Bidirectional
Terminal	Matte Tin-plated leads, Solderability per JESD22-B102

Soldering Parameters

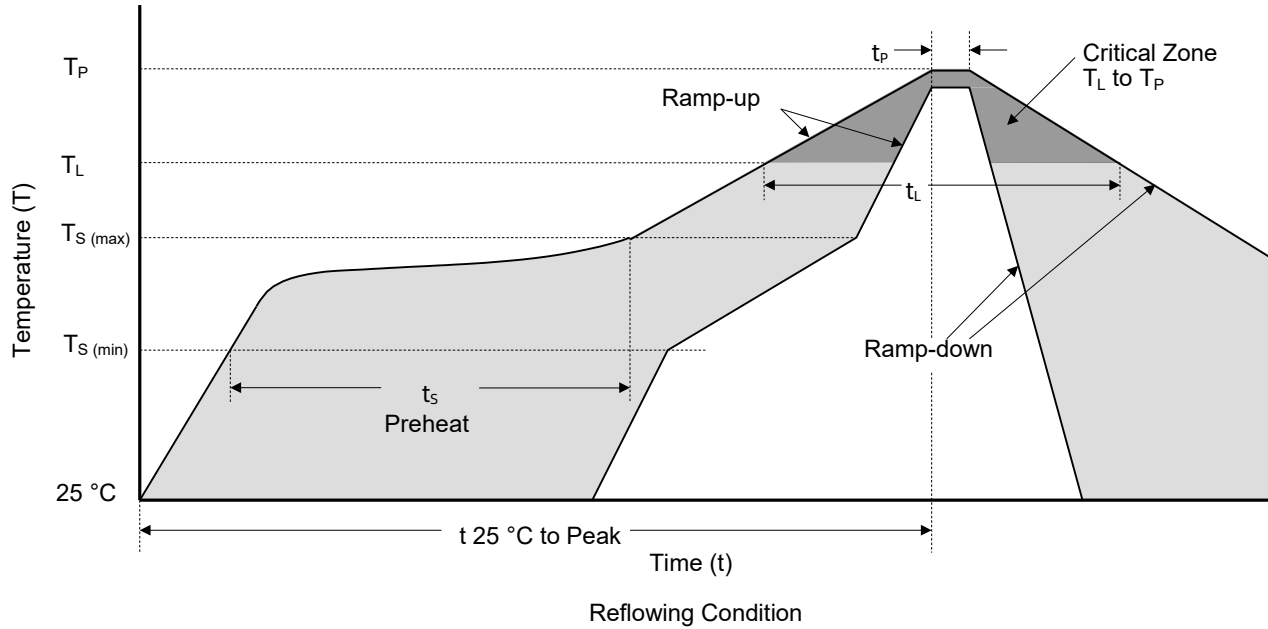

Reflow Soldering Parameters		Lead-Free Assembly
Pre-heat	Temperature Min ($T_{S (min)}$)	150 °C
	Temperature Max ($T_{S (max)}$)	200 °C
	Time (min to max) (t_s)	60 ~ 120 seconds
Average Ramp Up Rate (Liquidus Temp (T_L) to Peak)		3 °C / second max.
$T_{S (max)}$ to T_L Ramp-up Rate		3 °C / second max.
Reflow	Temperature (T_L) (Liquidus)	217 °C
	Time (min to max) (t_L)	60 ~ 150 seconds
Peak Temperature (T_P)		260 ^{+0/-5} °C
Time of within 5 °C of Actual Peak Temperature (t_p)		20 ~ 40 seconds
Ramp-down Rate		6 °C / second max.
Time from 25 °C to Peak Temperature		8 Minutes max.
Do Not Exceed		260 °C

Packaging Information

Tape	Symbol	Dimension (mm)
	W	16.00 + 0.3 / - 0.1
	P ₀	4.00 ± 0.10
	P ₁	8.00 ± 0.10
	P ₂	2.00 ± 0.10
	D ₀	1.55 ± 0.05
	D ₁	1.55 ± 0.05
	E	1.75 ± 0.10
	F	7.50 ± 0.10
	A ₀	6.15 ± 0.10
	B ₀	8.30 ± 0.10
	K ₀	2.48 ± 0.10
	T	0.30 ± 0.05

Reel Size	13" Reel	
	A	330 mm
	C	13.2 mm
	W ₁	16.4 mm

Part Number	Package	QTY (Reel)	Packaging Option	Packaging Specification
ASMDxxx-XX	DO-214AB	3000 PCS	Tape & Reel – 16 mm tape/13" reel	EIA STD RS-481



ATTENTION

Usage

1. TVS must be operated in the specified ambient temp.
2. Do not clean the TVS with strong polar solvent such as ketone, esters, benzene and halogenated hydrocarbon, to avoid damaging the encapsulating layer.
3. Please do not apply severe vibration, shock or pressure to TVS, to avoid element cracking.

Replacement

1. If TVS is visually damaged, please replace it.
2. TVS is a non-repairable product. For safety sake, please use equivalent TVS for replacement.

Storage

1. Storage Temp. Range: (-55 to 150) °C.
2. Do not store the TVS at the high temp., high humidity or corrosive gas environment, to avoid influencing the solder-ability of the lead wires. The product shall be used up within 1 year after receiving the goods.

Environmental Conditions

1. TVS should not be exposed to the open air, nor direct sunshine.
2. TVS should avoid rain, water vapor or other condition of high temp. and high humidity.
3. TVS should avoid sand dust, salt mist, or other harmful gases.

Max. Typical Capacitance of TVS

The typical capacitance of TVS is listed in the specifications. Designers may refer to it when designing TVS in High frequency circuit.

Installation Mechanical Stress

1. Do not knock TVS when installing, to avoid mechanical damage.
2. Please do not apply severe vibration, shock or pressure to TVS, to avoid surface resin or element cracking.